

**APPENDIX IIA**  
**ADVANCE PASSENGER INFORMATION GUIDELINES**

**Appendix IIA :**  
**Guide de mise en oeuvre du message PAXLST**

**(DISPONIBLE EN ANGLAIS UNIQUEMENT)**

Pour les modifications apportées aux lignes directrices de mise en œuvre de message, s'il vous plaît voir la version anglaise.

**WCO/IATA/ICAO PASSENGER LIST MESSAGE (PAXLST) IMPLEMENTATION GUIDE**

**October 2015**

**Version 5.0**

***As this Guide is considered to be a living document, potential developers and users of the PAXLST message are recommended to confirm with the WCO, IATA or ICAO that they are in possession of the latest version.***

# PASSENGER LIST MESSAGE (PAXLST) IMPLEMENTATION GUIDE

## TABLE OF CONTENTS

<b>1.0</b>	<b>INTRODUCTION</b> .....	<b>2</b>
<b>2.0</b>	<b>MESSAGE RELATIONSHIPS</b> .....	<b>3</b>
<b>3.0</b>	<b>MESSAGE STRUCTURE FOR THE PAXLST MESSAGE</b> .....	<b>5</b>
3.1	APPLICATION SEGMENTS USED IN THE WCO/IATA/ICAO PAXLST MESSAGE5	
3.2	UNITED NATIONS SERVICE SEGMENTS .....	5
4.1	UNA: SERVICE STRING ADVICE .....	8
4.2	UNB: INTERCHANGE HEADER .....	9
4.3	UNG: FUNCTIONAL GROUP HEADER .....	11
4.4	UNH: MESSAGE HEADER .....	13
4.5	BGM: BEGINNING OF MESSAGE .....	15
4.6	RFF: REFERENCE .....	17
4.7	NAD: NAME AND ADDRESS - GR. 1 .....	17
4.8	COM: COMMUNICATION CONTACT - GR. 1 .....	19
4.9	TDT: DETAILS OF TRANSPORT- GR. 2 .....	20
4.10	LOC: PLACE/LOCATION IDENTIFICATION - GR.3 .....	22
4.11	DTM: DATE/TIME/PERIOD - GR. 3 .....	24
4.12	NAD: NAME AND ADDRESS - GR. 4.....	25
4.13	ATT: ATTRIBUTE - GR. 4 .....	27
4.14	DTM: DATE/TIME/PERIOD - GR. 4 .....	28
4.15	MEA: MEASUREMENTS - GR. 4.....	29
4.16	GEI: PROCESSING INFORMATION - GR. 4.....	30
4.17	FTX: FREE TEXT - GR. 4.....	31
4.18	LOC: PLACE/LOCATION IDENTIFICATION - GR. 4.....	32
4.19	COM: COMMUNICATION CONTACT - GR. 4 .....	34
4.20	EMP: EMPLOYMENT DETAILS - GR. 4 .....	35
4.21	NAT: NATIONALITY - GR. 4.....	37
4.22	RFF: REFERENCE - GR. 4 .....	39
4.23	DOC: DOCUMENT/MESSAGE DETAILS - GR. 5.....	40
4.24	DTM: DATE/TIME/PERIOD - GR. 5 .....	41
4.25	LOC: PLACE/LOCATION IDENTIFICATION - GR. 5.....	42
4.26	CNT: CONTROL TOTAL .....	43
4.27	UNT: MESSAGE TRAILER .....	44
4.28	UNE: FUNCTIONAL GROUP TRAILER.....	45
4.29	UNZ: INTERCHANGE TRAILER .....	46
	<b>APPENDIX A – DATA ELEMENT LIST</b> .....	<b>51</b>

## Change log

	<b>Description</b>	<b>Date</b>	<b>Remarks</b>
1.	Update of the PAXLST MIG	25/02/2013	Based on Data Maintenance Requests received in the 5 <sup>th</sup> and the 6 <sup>th</sup> meetings of the API Contact Committee
2	Update of the PAXLST MIG	31/10/2013	Based on discussions at the 7 <sup>th</sup> meeting of the API Contact Committee and follow-up work
3	Update of the PAXLST MIG	10/10/2014	Based on discussions at the 8 <sup>th</sup> meeting of the API Contact Committee and follow-up work
4	Update of the PAXLST MIG	07/10/2015	Based on discussions at the 9 <sup>th</sup> meeting of the API Contact Committee and follow-up work

# PASSENGER LIST MESSAGE (PAXLST) IMPLEMENTATION GUIDE

***This Document includes all the data requirements agreed by the WCO, IATA and ICAO and should be used as a basis for development of the air mode PAXLST message.***

***The WCO Council formally adopted the Advanced Passenger Information Guidelines and this Implementation Guide in July 2016.***

***IATA formally adopted the revised PAXLST message in TBD.***

***ICAO approved the revised PAXLST message in TBD.***

## 1.0 INTRODUCTION

The first edition of the Advanced Passenger Information Guidelines was published in 1993 and included the data requirements that carriers were required to provide when reporting Advanced Passenger Information (API) to Border Control Agencies.

The Guideline also contained the specifications for the WCO/IATA subset of the UN/EDIFACT PAXLST message that had been designed as multi-modal, multi-functional message.

In October 2002, the WCO and IATA jointly updated the API Guidelines and reached agreement on a revised set of API data requirements.

This finalized set, adopted jointly by the WCO, IATA and ICAO in 2010, and last revised in 2015 includes additional data elements, in response to heightened security concerns within the air travel industry. This document represents the maximum number of data elements that carriers may be required to provide when reporting Advanced Passenger Information (API) to Border Control Agencies.

Carriers need to be aware that some Border Control Agencies may not require all elements contained within each message set.

The set of requirements have been mapped into the WCO/IATA/ICAO subset of the UN/EDIFACT PAXLST and CUSRES messages and this detailed Message Implementation Guide has been developed by the WCO/IATA/ICAO API Contact Committee.

The purpose of this Guide is to aid border control Agencies and carriers in understanding the UN/EDIFACT PAXLST and CUSRES messages before beginning detailed development and implementation.

This Guide contains the necessary message branching diagrams and describes the function and use of each segment within its relative position within the message sets.

Examples on a segment basis and on a message basis are also included.

## 2.0 MESSAGE RELATIONSHIPS

The UN/EDIFACT PAXLST message set may be implemented as a standalone batch message for which there is no direct response message, or implemented within a bi-directional, interactive API message exchange process incorporating both UN/EDIFACT PAXLST and CUSRES message sets

The agreed data requirements for the WCO/IATA/ICAO PAXLST message are defined in Section 8 of the Advanced Passenger Information Guidelines and for the purpose of message design are reproduced as follows:

### **Flight Information (Header Data)**

#### **(Please see Section 8.1.4)**

- Airline Code and Flight Number
- Last Place/Port of Call for Aircraft
- Place/Port of Initial Arrival for Aircraft
- Scheduled Local Departure Dates/Times
- Scheduled Local Arrival Dates/Time
- Subsequent Place(s)/Port(s) of Call within the Country (for Progressive Flights)
- Place/Port of Final Destination within the Country (for Progressive Flights)
- Number of Passengers and Number of Crew Members

### **Data relating to each individual passenger or crew member:**

- Core Data Elements as may be found in the Machine Readable Zone of the Official Travel Document (See Section 8.1.5(a))
  - Official Travel Document Number
  - Issuing State or Organization of the Official Travel Document
  - Official Travel Document Type
  - Expiration Date of Official Travel Document
  - Surname/Given Name(s)
  - Nationality
  - Date of Birth
  - Gender
- Additional Data elements as available in the airline system (see 8.1.5(b))
  - Seat Assignment
  - Bag Tag Identification
  - Checked Bag Quantity
  - Traveller's Status
  - Place/Port of Original Embarkation
  - Place/Port of Clearance
  - Place/Port of Onward Foreign Destination
  - Passenger Name Record Locator Number (or unique identifier)
- Additional data not normally found in Airline systems and which must be collected by, or on behalf of the Airline (See Section 8.1.5(c))
  - Visa Number
  - Issue Date of the Visa
  - Place of Issuance of the Visa
  - Other Document Number Used for Travel

Type of Other Document Used for Travel

Primary Residence

Address

City

State/Province/County

Postal Code

Country

Destination Address

Address

City

State/Province/County

Postal Code

Place of Birth

Country of Primary Residence

- Contact Information for the person or entity responsible for the message content
- Passenger Reference Number (supplement to Passenger Name Record Locator)
- Information Verified indicator
- Passenger Contact information

Accordingly, provisional allowance is made for inclusion of these data consistent with UN/EDIFACT construction rules.

### 3.0 MESSAGE STRUCTURE FOR THE PAXLST MESSAGE

This message specification is based on the UN/EDIFACT Passenger List (PAXLST) Message and is specific to the air mode. It permits the transfer of passenger and crew member data from an airline to a Border Control Authority or other designated authority in the country of arrival (or departure) of the means of transport.

The basic concept of the PAXLST message is that there is one message for all passengers on the specified flight (or individual interactive PAXLST messages on a passenger-by-passenger basis) and a separate message used to report all crew members on that flight.

#### 3.1 APPLICATION SEGMENTS USED IN THE WCO/IATA/ICAO PAXLST MESSAGE

The segments included in the air mode implementation of PAXLST are:

ATT	Attribute
BGM	Beginning of Message
CNT	Control Total
COM	Communication Contact
EMP	Employment Detail
DOC	Document/Message Details
DTM	Date/Time/Period
FTX	Free Text
GEI	Processing Information
LOC	Place/Location Identification
MEA	Measurements
NAD	Name and Address
NAT	Nationality
RFF	Reference
TDT	Details of Transport
UNA	Service Segment Advice
UNB	Interchange Header
UNE	Functional Group Trailer
UNG	Functional Group Header
UNH	Message Header
UNT	Message Trailer
UNZ	Interchange Trailer

It should be noted that the UN/EDIFACT PAXLST message includes other segments not included above.

#### 3.2 UNITED NATIONS SERVICE SEGMENTS

The UN Service Segments UNA, UNB and UNZ should be implemented as they are described in ISO 9735 Application Level Syntax Rules - Version 4. The use of the UNG and UNE segment pair is optional within UN/EDIFACT message syntax, based upon bilateral agreement.

Data requirements for these segments are determined on a bilateral basis between individual carriers and respective Border Control Agencies.

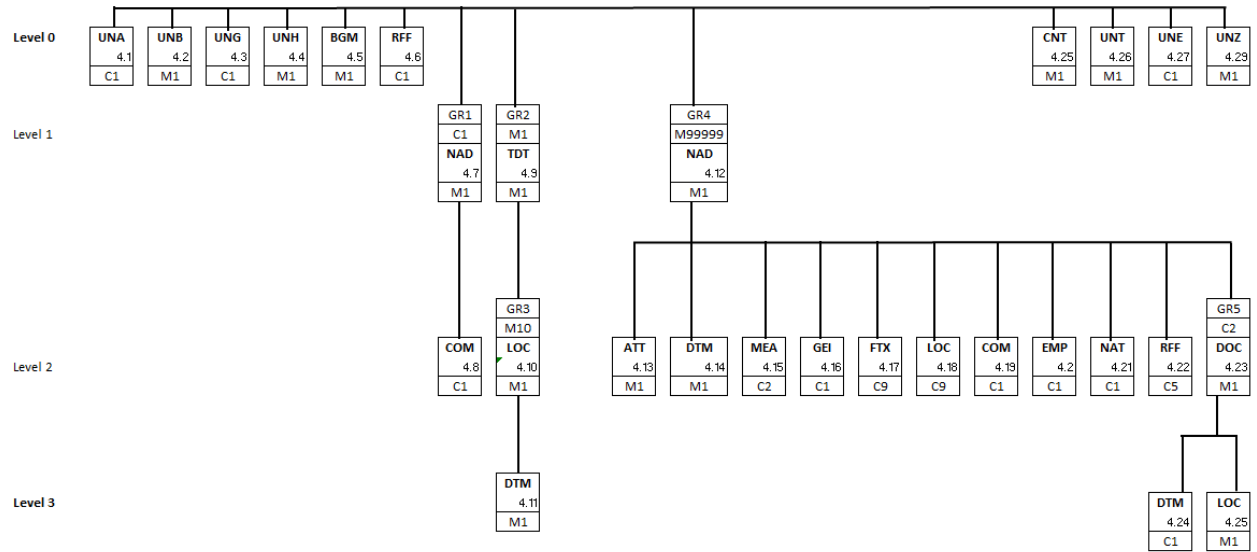

## 4.0 SEGMENT DETAILS FOR USE IN THE PAXLST MESSAGE

This Section provides a detailed table of each segment, in their relative position within the message, that may be required for the air mode PAXLST message.

Each table contains the UN/EDIFACT composite element and data element names, numbers and formats.

The table also contains the PAXLST format and status (Mandatory, Conditional or Not Applicable) of the elements within the segment, the number of repetitions, and the indication of a code set.

The elements that may be used in each segment are indicated by **bolding** the element name.

**M** or **C** in the Status column indicates a Mandatory or Conditional element.

**N/A** in the Status column indicates that there is no requirement to populate this field.

Additional comments on the use of the elements are also provided.

Code set values that may be used in each segment are provided in **BOLD** text. Examples of other values are provided in ***BOLD ITALICISED*** text.

4.1 UNA: SERVICE STRING ADVICE

Function: The Service String Advice (UNA) is Conditional and provides the capability to specify the service characters (delimitation syntax) used within the interchange. The UNA service string advice **must** be used if the service characters differ from the defaults as identified in ISO 9735 EDIFACT Syntax Rules. The UNA is optional if the default characters are used.

When used, the service string advice shall appear immediately before the interchange header segment. The service string advice shall begin with the upper case characters UNA immediately followed by six characters in the order shown below. The same character shall not be used in more than one position of the UNA.

Default Service Characters		
Name	Graphic Representation	Functionality
Colon	:	Component Data Element Separator
Plus sign	+	Data Element Separator
Period	.	Decimal mark
Question mark	?	Release Character
Asterisk	*	Repetition Separator
Apostrophe	'	Segment Terminator

Composite/Data Element	No.	Field Type	Comm Usage	Status	Max Rep	Code Set	Comp.	Values / Comments
COMPONENT DATA ELEMENT SEPARATOR	UNA1	n1	n1	M	-	-	-	
DATA ELEMENT SEPARATOR	UNA2	n1	n1	M	-	-	-	
DECIMAL MARK	UNA3	n1	n1	M	-	-	-	
RELEASE CHARACTER	UNA4	n1	n1	M	-	-	-	
REPETITION SEPARATOR	UNA5	n1	n1	M	-	-	-	
SEGMENT TERMINATOR	UNA6	n1	n1	M	-	-	-	

**Example: UNA:+.?)** In this example, the right-parens represents the exception to the default Segment Terminator.

#### 4.2 UNB: INTERCHANGE HEADER

Function: To start, identify and specify an interchange.

The conditional Status (C) of elements within this segment is used to indicate that Border Control Agencies may establish bilateral requirements for these data elements.

Composite/Data Element	No.	Field Type	Comm Usage	Status	Max Rep	Code Set	Comp.	Values / Comments
<b>SYNTAX IDENTIFIER</b>	S001	-	-	M	1	-	-	
Syntax identifier	0001	a4	a4	M	1	-	S001	<b>UNOA</b>
Syntax version number	0002	n1	n1	M	1	-	S001	<b>4</b>
<b>INTERCHANGE SENDER</b>	S002	-	-	M	1	-	-	
Sender identification	0004	an..35	an..35	M	1	-	S002	<b>'AIRLINE1'</b> Sender of the message
Partner identification code qualifier	0007	an..4	N/A	C	-	-	-	
Address for reverse routing	0008	an..14	N/A	C	-	-	-	
<b>INTERCHANGE RECEIVER</b>	S003	-	-	M	1	-	-	
Recipient identification	0010	an..35	an..35	M	1	-	S003	<b>'NZCS'</b> (for example) Receiver of the message. (This value is assigned by the implementing agency).
Partner identification code qualifier	0007	an..4	N/A	C	-	-	-	
Routing address	0014	an..14	N/A	C	-	-	-	
<b>DATE AND TIME OF PREPARATION</b>	S004	-	-	M	1	-	-	
Date of preparation	0017	n6	n6	M	1	-	S004	<b>'130628'</b> The default format is 'YYMMDD' (n6)
Time of preparation	0019	n4	n4	M	1	-	S004	<b>'0900'</b> The default format is 'HHMM' (n4)
<b>INTERCHANGE CONTROL REFERENCE</b>	0020	an..14	an..14	M	1	-	-	<b>'00000001'</b> Will be repeated in UNZ data element 0020
<b>RECIPIENTS REFERENCE PASSWORD</b>	S005	-	N/A	C	-	-	-	
Recipient reference password	0022	an..14	N/A	M	-	-	S005	
Recipient reference password qualifier	0025	an..2	N/A	C	-	-	S005	
<b>APPLICATION REFERENCE</b>	0026	an..14		C	-	-	-	
<b>PROCESSING PRIORITY CODE</b>	0029	a1		C	-	-	-	

Composite/Data Element	No.	Field Type	Comm Usage	Status	Max Rep	Code Set	Comp.	Values / Comments
ACKNOWLEDGEMENT REQUEST	0031	n1		C				
COMMUNICATIONS AGREEMENT ID	0032	an..35		C				
TEST INDICATOR	0035	n1		C				

**Example**

**UNB+UNOA:4+AIRLINE1+NZCS+130628:0900+000000001'**

#### 4.3 UNG: FUNCTIONAL GROUP HEADER

Function: To head, identify and specify a Functional Group.

The conditional Status (C) of elements within this segment is used to indicate that Border Control Agencies may establish bilateral requirements for these data elements.

Composite/Data Element	No.	Field Type	Comm Usage	Status	Max Rep	Code Set	Comp.	Values / Comments
<b>FUNCTIONAL GROUP IDENTIFICATION</b>	0038	an6	an6	M	1	-	-	<b>PAXLST</b>
<b>APPLICATION SENDER IDENTIFICATION</b>	S006	-	-	M	1	-	-	
<b>Application Sender identification</b>	0040	an..35	an..35	M	1	-	S006	<b>'AIRLINE1'</b> Sending Application
Partner identification code qualifier	0007	an..4	N/A	C	-	-	S006	
<b>APPLICATION RECIPIENT IDENTIFICATION</b>	S007	-	-	M	1	-	-	
<b>Application Recipient identification</b>	0044	an..35	an..35	M	1	-	S007	<b>'NZCS'</b> (for example) Receiving Application  (This value is assigned by the implementing agency).
Partner identification code qualifier	0007	an..4	N/A	C	-	-	S007	
<b>DATE AND TIME OF PREPARATION</b>	S004	-	-	M	1	-	-	
<b>Date of preparation</b>	0017	n6	n6	M	1	-	S004	<b>'130628'</b> The default format is 'YYMMDD' (n6)
<b>Time of preparation</b>	0019	n4	n4	M	1	-	S004	<b>'0900'</b> The default format is 'HHMM' (n4)
<b>FUNCTIONAL GROUP REFERENCE NUMBER</b>	0048	an..14	an..14	M	1	-	-	<b>'000000001'</b> Will be repeated in UNE data element 0048
<b>CONTROLLING AGENCY MESSAGE VERSION</b>	0051	an..2	an..2	M	1	-	-	<b>UN</b>
<b>Message Type Version Number</b>	0052	an..3	an..3	M	1	-	S008	<b>'D' (for example)</b>
<b>Message Type Release Number</b>	0054	an..3	an..3	M	1	-	S008	<b>'15B'</b> <b>See Note.</b>
Association assigned code	0057	an..6		C				
<b>APPLICATION PASSWORD</b>	0058	an..14		C				

#### Example

**UNG+PAXLST+AIRLINE1+NZCS+130628:0900+000000001+UN+D:15B'**

Note: Border Control Agencies may establish bilateral requirements for the value placed in this data element.

#### 4.4 UNH: MESSAGE HEADER

Function: To identify and specify the PAXLST message.

The conditional Status (C) of elements within this segment is used to indicate that Border Control Agencies may establish bilateral requirements for these data elements.

Composite/Data Element	No.	Field Type	Comm Usage	Status	Max Rep	Code Set	Comp.	Values / Comments
<b>MESSAGE REFERENCE NUMBER</b>	0062	an..14	an..14	M	1	-	-	'MSG001' Will be repeated in UNT data element 0062
<b>MESSAGE IDENTIFIER</b>	S009	-	-	M	1	-	-	
Message type	0065	an..6	a6	M	1	-	S009	<b>PAXLST</b>
Message version number	0052	an..3	a1	M	1	-	S009	<b>D</b>
Message release number	0054	an..3	an2	M	1	-	S009	'15B' <b>See Note2.</b>
Controlling agency, coded	0051	an..2	a2	M	1	-	S009	<b>UN</b>
Association assigned code	0057	an..6	a4	M	1	-	S009	<b>IATA</b> See Note1
Code list directory version number	0110	an..6		C			S009	
Message type sub-function identification	0113	an..6		C			S009	
<b>COMMON ACCESS REFERENCE</b>	0068	an..35		C	1			
<b>STATUS OF THE TRANSFER</b>	S010			C	1			
Sequence of transfers	0070	n..2		M			S010	
First and last transfer	0073	a1		C			S010	
<b>MESSAGE SUBSET IDENTIFICATION</b>	S016			C	1			
Message subset identification	0115	an..14		M			S016	
Message subset version number	0116	an..3		C			S016	
Message subset release number	0118	an..3		C			S016	
Controlling agency, coded	0051	an..3		C			S016	
<b>MESSAGE IMPLEMENTATION GUIDELINE IDENTIFICATION</b>	S017			C	1			
Message implementation guideline identification	0121	an..14		M	1		S017	
Message implementation guideline version number	0122	an..3		C			S017	
Message implementation guideline release number	0124	an..3		C			S017	
Controlling agency, coded	0051	an..3		C			S017	
<b>SCENARIO IDENTIFICATION</b>	S018			C	1			
Scenario identification	0127	an..14		M			S018	
Scenario version number	0128	an..3		C			S018	
Scenario release number	0130	an..3		C			S018	
Controlling agency, coded	0051	an..3		C			S018	

**Example**

`UNH+MSG001+PAXLST:D:15B:UN:IATA'`

**Note1**

The use of code value 'IATA' in data element 0057 is used to indicate that airport and airline codes are IATA assigned codes.

**Note2:**

These Guidelines refer to the latest available publication of the PAXLST message of the UN/EDIFACT Directory. Border Control Agencies may already have existing guidelines based upon a previously published API Guideline version.

4.5 BGM: BEGINNING OF MESSAGE

Function: To indicate whether the PAXLST message is a passenger or crew list message.

Composite/Data Element	No.	Field Type	Comm. Usage	Status	Max Rep.	Code Set	Comp.	Values / Comments
<b>DOCUMENT/ MESSAGE NAME</b>	C002	-	-	M	1	-	-	
<b>Document name code</b>	1001	an..3	n3	M	1	Yes	C002	<b>250, 745, 266, 336, 655</b>
Code list identification code	1131	an..17	-	N/A	-	-	-	
Code list responsible agency code	3055	an..3	-	N/A	-	-	-	
Document name	1000	an..35	-	N/A	-	-	-	
<b>DOCUMENT/MESSAGE IDENTIFICATION</b>	C106							
Document identifier	1004	an..35	an..4	C				See examples below in Table 4.5.1
Version identifier	1056	an..9		N/A				
Revision identifier	1060	an..6		N/A				
<b>MESSAGE FUNCTION CODE</b>	1225	an..3		N/A				
<b>RESPONSE TYPE CODE</b>	4343	an..3		N/A				

**Example**

- BGM+745'** Indicates passenger list
- BGM+250'** Indicates crew list declaration
- BGM+266'** **Indicates change in flight status@**
- BGM+336'** Indicates master crew list declaration
- BGM+655'** Indicates Gate Pass\*

\*Note: A gate pass is an authorization for a non-travelling person to access the sterile area of airports for the purpose of accompanying a ticketed traveller. (Presently used only in the United States.)

@ used in interactive API messages only.

**Table 4.5.1**

Document Name Code	Document Identifier Code	Meaning	Example
745	CP	Change Passenger Data	BGM+745+CP
745	XR	Cancel Reservation	BGM+745+XR
745	RP	Reduction in Party	BGM+745+RP
266	CL	Flight Close (only)	BGM+266+CL
266	CLNB	Flight Close w/ identified Passengers <i>not</i> on-board	BGM+266+CLNB
266	CLOB	Flight Close w/ identified Passengers on-board	BGM+266+CLOB
266	XF	Cancel Flight	BGM+266+XF
266	CF	Change Flight/Itinerary	BGM+266+CF

250	CL	Crew Flight Close (only)	BGM+250+CL
250	CLNB	Crew Flight Close w/ identified Crew <i>not</i> on-board	BGM+250+CLNB
250	CLOB	Crew Flight Close w/ identified Crew on-board	BGM+250+CLOB

**Note:**

Crew flight close process may not be implemented by aircraft operators.

Flight close process is normally implemented in iAPI system instead of batch, and associated with Departure Control Systems where seats are assigned to passengers.

It should also be noted that some states require pre and post departure Crew messaging, for example the UK.

4.6 RFF: REFERENCE

Function: To specify a transaction reference number.

Composite/Data Element	No.	Field Type	Comm. Usage	Status	Max Rep.	Code Set	Comp.	Values / Comments
<b>REFERENCE</b>	C506			M	1	-	-	
<b>Reference code qualifier</b>	1153	an..3	a3	M	1	Yes	C506	<b>TN</b>
<b>Reference identifier</b>	1154	an..70	an..25	M	1	-	C506	<b>'BA123456789'</b>
Document line identifier	1156	an..6	-	N/A	-	-	-	
Version identifier	1056	an..9	-	N/A	-	-	-	
Revision identifier	1060	an..6	n..3	C	-	-	-	<b>'2'</b>

**Example**

**RFF+TN:BA123456789'** Indicates transaction reference number BA123456789 assigned by an airline system.

**RFF+TN:OZ56789034:::2'** Indicates transaction reference number OZ56789034 assigned by an airline system. The Revision Identifier may optionally be used to identify this passenger data submission as the second submission for this passenger (i.e updated passenger data).

4.7 NAD: NAME AND ADDRESS - GR. 1

Function: To specify a contact responsible for the message content.  
This may either be an assigned profile or the name of the contact person.

If the 'name' (data elements 3036) is used, then contact details must be provided in the following COM (Communication Contact) segment.

Composite/Data Element	No.	Field Type	Comm. Usage	Status	Max Rep.	Code Set	Comp.	Values / Comments
<b>PARTY FUNCTION CODE QUALIFIER</b>	3035	an..3	a2	M	1	Yes	--	<b>MS</b>
<b>PARTY IDENTIFICATION DETAILS</b>	C082	-	-	C	1	-	-	Used if a Profile has been assigned
<b>Party identifier</b>	3039	an..35	an..35	M	1	-	C082	<b>'ABC9876'</b>
Code list identification code	1131	an..17	-	N/A	-	-	-	
Code list responsible agency code	3055	an..3	-	N/A	-	-	-	
<b>NAME AND ADDRESS</b>	C058			N/A				
Name and address description	3124	an..35		N/A				
Name and address description	3124	an..35		N/A				
Name and address description	3124	an..35		N/A				
Name and address description	3124	an..35		N/A				
Name and address description	3124	an..35		N/A				

Composite/Data Element	No.	Field Type	Comm. Usage	Status	Max Rep.	Code Set	Comp.	Values / Comments
<b>PARTY NAME</b>	C080	-	-	C	1	-	-	Used if profile has not been established.
<b>Party Name</b>	3036	an..35	an..35	M	1	--	C080	' <b>WILLIAMS</b> ' Contact Surname
<b>Party Name</b>	3036	an..35	an..35	M	1	-	C080	' <b>JANE</b> ' Contact First Name
Party Name	3036	an..35	-	N/A	-	-	-	
Party Name	3036	an..35	-	N/A	-	-	-	
Party Name	3036	an..35	-	N/A	-	-	-	
Party name format code	3045	an..3		N/A	-	-	-	
<b>STREET</b>	C059			N/A				
Street and number or post office box identifier	3042	an..35		N/A				
Street and number or post office box identifier	3042	an..35		N/A				
Street and number or post office box identifier	3042	an..35		N/A				
Street and number or post office box identifier	3042	an..35		N/A				
<b>CITY NAME</b>	3164	an..35		N/A				
<b>COUNTRY SUB-DIVISION DETAILS</b>	C819			N/A				
Country sub-division name code	3229	an..9		N/A				
Code list identification code	1131	an..17		N/A				
Code list responsible agency code	3055	an..3		N/A				
Country sub-entity name	3228	an..70		N/A				
<b>POSTAL IDENTIFICATION CODE</b>	3251	an..17		N/A				
<b>COUNTRY IDENTIFIER</b>	3207	an..3		N/A				

### Examples

1. NAD+MS+ABC9876' Indicates that a profile has been established for this contact with this assigned identification
2. NAD+MS+++WILLIAMS:JANE' Indicates the name of the contact person

4.8 COM: COMMUNICATION CONTACT - GR. 1

Function: To specify the communication number(s) of the person responsible for the message content. Up to 3 communication numbers can be provided.

Data must be provided if no contact profile has been established.

Composite/Data Element	No.	Field Type	Comm Usage	Status	MaxRep.	Code Set	Comp.	Values / Comments
<b>COMMUNICATION CONTACT</b>	C076	-	-	M	3	-	-	
<b>Communication address identifier</b>	3148	an..512	an..35	M	1	-	C076	'202 628 9292'
<b>Communication address code qualifier</b>	3155	an..3	a2	M	1	Yes	C076	EM, FX, TE

**Notes**

1. The contact details for the 'physical transmitter' of the message may be supplied in data element 0004 in the UNB segment.

**Example**

**COM+202 628 9292:TE+202 628 4998:FX+davidsonr.at.iata.org:EM'**

Indicates telephone number, fax number and email address of the message sender/contact.

Note: When reporting email addresses, special consideration should be given to any special characters appearing in the email address and potential impact to the syntax delimitation defined in the UNA segment.

## 4.9 TDT: DETAILS OF TRANSPORT- GR. 2

Function: To identify the flight by IATA airline designator and flight number.

Composite/Data Element	No.	Field Type	Comm. Usage	Status	Max Rep	Code Set	Comp	Values / Comments
<b>TRANSPORT STAGE CODE QUALIFIER</b>	8051	an..3	n2	M	1	Yes	-	<b>20 – For arriving or departing flight</b> <b>34 – For Over-flight</b>
<b>MEANS OF TRANSPORT JOURNEY IDENTIFIER</b>	8028	an..17	an..8	M	1	-	-	<b>'DL123'</b>
<b>MODE OF TRANSPORT</b>	C220			N/A				
Transport mode name code	8067	an..3		N/A				
Transport mode name	8066	an..17		N/A				
<b>TRANSPORT MEANS</b>	C001			N/A				
Transport means description code	8179	an..8		N/A				
Transport means description	8178	an..17		N/A				
<b>CARRIER</b>	C040			N/A				
Carrier identifier	3127	an..17	an..3	C				<b>'DL'</b>
Code list identification code	1131	an..17		N/A				
Code list responsible agency code	3055	an..3		N/A				
Carrier name	3126	an..35		N/A				
<b>TRANSIT DIRECTION INDICATOR CODE</b>	8101	an..3		N/A				
<b>EXCESS TRANSPORTATION INFORMATION</b>	C401			N/A				
Excess transportation reason code	8457	an..3		N/A				
Excess transportation responsibility code	8459	an..3		N/A				
Customer shipment authorisation identifier	7130	an..17		N/A				
<b>TRANSPORT IDENTIFICATION</b>	C222			N/A				
Transport means identification name identifier	8213	an..35		N/A				
Code list identification code	1131	an..17		N/A				
Code list responsible agency code	3055	an..3		N/A				
Transport means identification name	8212	an..70		N/A				

Composite/Data Element	No.	Field Type	Comm. Usage	Status	Max Rep	Code Set	Comp	Values / Comments
Transport means nationality code	8453	an..3		N/A				
TRANSPORT MEANS OWNERSHIP INDICATOR CODE	8281	an..3		N/A				
POWER TYPE	C003			N/A				
Power type cod	7041	an..3		N/A				
Code list identification code	1131	an..17		N/A				
Code list responsible agency code	3055	an..3		N/A				
Power type description	7040	an..17		N/A				

**Example**

**TDT+20+DL123+++DL'** Indicates flight identification DL123, Carrier Code DL  
**TDT+20+EK456'** Indicates flight identification EK456, Carrier Code not required  
**TDT+34+AF986+++AF'** Indicates flight identification AF986, Carrier Code AF, Over-flight.

4.10 LOC: PLACE/LOCATION IDENTIFICATION - GR.3

Function: To identify the arrival and departure airports relating to the specified flight.  
 Airport codes are published in the IATA Airline Coding Directory.

Composite/Data Element	No.	Field Type	Comm Usage	Status	MaxRep	Code Set	Comp.	Values / Comments
<b>LOCATION FUNCTION CODE QUALIFIER</b>	3227	an..3	n..3	M	1	Yes	-	<b>87, 92, 125, 130</b>
<b>LOCATION IDENTIFICATION</b>	C517	-	-	M	1	-	-	IATA Location Identifiers (Airport Codes)
<b>Location name code</b>	3225	an..35	a3	M	1	-	C517	'YUL'
Code list identification code	1131	an..17	-	N/A	-	-	-	
Code list responsible agency code	3055	an..3	-	N/A		-	-	
Location name	3224	an..256	-	N/A		-	-	
<b>RELATED LOCATION ONE IDENTIFICATION</b>	C519			N/A				
First related location identifier	3223	an..35		N/A				
Code list identification code	1131	an..17		N/A				
Code list responsible agency code	3055	an..3		N/A				
First related location name	3222	an..70		N/A				
<b>RELATED LOCATION TWO IDENTIFICATION</b>	C553			N/A				
Second related location identifier	3233	an..35		N/A				
Code list identification code	1131	an..17		N/A				
Code list responsible agency code	3055	an..3		N/A				
Second related location name	3232	an..70		N/A				
<b>RELATION CODE</b>	5479	an..3		N/A				

**Examples**

- For a single sector progressive flight departing Brussels to New York, the following data would be provided.
  - LOC+125+BRU'** Indicates the last airport of departure from a foreign country, i.e. Brussels National
  - LOC+87+JFK'** Indicates the first airport of arrival in the country of destination, i.e. John F Kennedy International, New York
- For a multi-sector progressive flight departing Heathrow to Vancouver via Montreal and Ottawa, the following data would be provided.
  - LOC+125+LHR'** Indicates the last airport of departure from a foreign country, i.e. London Heathrow

<b>LOC+87+YUL'</b>	Indicates the first airport of arrival in the country of destination, i.e. Montreal Dorval
<b>LOC+92+YOW'</b>	Indicates the next airport in the country of destination, i.e. Ottawa International
<b>LOC+130+YVR'</b>	Indicates the final destination airport in the country of destination, i.e. Vancouver International

4.11 DTM: DATE/TIME/PERIOD - GR. 3

Function: To specify the departure and arrival dates for a flight.  
If required, departure and arrival times may also be specified.

All dates and times will be provided in LOCAL time.

Composite/Data Element	No.	Field Type	Comm Usage	Status	MaxRep.	Code Set	Comp	Values / Comments
<b>DATE/TIME/ PERIOD</b>	C507	-	-	M	1	-	-	
<b>Date or time or period function code qualifier</b>	2005	an..3	n3	M	1	Yes	C507	<b>189, 232</b>
<b>Date or time or period value</b>	2380	an..35	n6 or n10	M	1	-	C507	The default format is 'YYMMDD' (n6) <b>'130628'</b> Other format is 'YYMMDDHHMM' (n10). <b>'1306281205'</b>
<b>Date or time or period format code</b>	2379	an..3	n3	C	1	Yes	C507	<b>'201'</b> If time (HHMM) is included in data element 2380

**Examples**

- DTM+189:1306281205:201'** Indicates the scheduled departure date and time of the flight, (i.e. June 28, 2013 at 12:05 hrs)  
Code 201 is used to indicate a YYMMDDHHMM format.
- DTM+232:130628'** Indicates the scheduled arrival date of flight (i.e June 28, 2013)

4.12 NAD: NAME AND ADDRESS - GR. 4

Function: To specify the names of passengers and crew aboard a specified flight.

The segment may also be used to specify either the address details of the country of residence or the address details while in a specific country.

Composite/Data Element	No.	Field Type	Comm. Usage	Status	MaxR ep.	Code Set	Comp.	Values / Comments
<b>PARTY FUNCTION CODE QUALIFIER</b>	3035	an..3	a..3	M	1	Yes	-	<b>DDT, DDU, FL, FM, ZZZ</b>
<b>PARTY IDENTIFICATION DETAILS</b>	C082			N/A				
Party identifier	3039	an..35		N/A				
Code list identification code	1131	an..17		N/A				
Code list responsible agency code	3055	an..3		N/A				
<b>NAME AND ADDRESS</b>	C058			N/A				
Name and address description	3124	an..35		N/A				
Name and address description	3124	an..35		N/A				
Name and address description	3124	an..35		N/A				
Name and address description	3124	an..35		N/A				
Name and address description	3124	an..35		N/A				
<b>PARTY NAME</b>	C080	-	-	M	1	-	-	Passenger or Crew Names
<b>Party Name</b>	3036	an..35	an..35	M	1	-	C080	'SMITH' Last name
<b>Party Name</b>	3036	an..35	an.. 35	C	1	-	C080	'JOAN' First given name (or initial)
<b>Party Name</b>	3036	an..35	an.. 35	C	1	-	C080	'A' Second given name (or initial)
Party Name	3036	an..35	-	N/A	-	-	-	
Party Name	3036	an..35	-	N/A	-	-	-	
Party name format code	3045	an..3	-	N/A	-	-	-	
<b>STREET</b>	C059	-	-	C	-	-	-	Street Address
<b>Street and number or post office box identifier</b>	3042	an..35	an...35	M	1	-	C059	'235 WESTERN ROAD SUITE 203'
Street and number or post office box identifier	3042	an..35	-	N/A	-	-	-	
Street and number or post office box identifier	3042	an..35	-	N/A	-	-	-	
Street and number or post office box identifier	3042	an..35	-	N/A	-	-	-	
<b>CITY NAME</b>	3164	an..35	an..35	C	1	-	-	'SLEAFORD'

Composite/Data Element	No.	Field Type	Comm. Usage	Status	MaxRep.	Code Set	Comp.	Values / Comments
<b>COUNTRY SUB-ENTITY DETAILS</b>	C819	-	-	C	1	-	-	State/Province/County Either a code in data element 3229 or a name in data element 3228
<b>Country sub-entity name code</b>	3229	an..9	an..9	C	1	-	C819	' <b>FL</b> '
<b>Code list identification code</b>	1131	an..17	-	C	1	-	C819	No value required but element must be accounted for if data element 3228 included
<b>Code list responsible agency code</b>	3055	an..3	-	C	1	-	C819	No value required but element must be accounted for if data element 3228 included
<b>Country sub-entity name</b>	3228	an..70	an..35	C	1	-	C819	' <b>LINCS</b> '
<b>POSTAL IDENTIFICATION CODE</b>	3251	an..17	an..17	C	1	-	-	' <b>PE22 4T5</b> '
<b>COUNTRY NAME CODE</b>	3207	an..3	a3	C	1	-	-	' <b>GBR</b> ' ICAO codes in Doc 9303/ISO 3166

#### Examples

1. **NAD+FL+++SMITH:JOAN:A'** Indicates passenger with last name Smith, first name Joan and initial A
2. **NAD+FL+++WILLIAMS:JOHN:DONALD+235 WESTERN ROAD SUITE 203+SLEAFORD+:::LINCS+PE22 4T5+GBR'**  
Indicates passenger with last name Williams, first name John, and second name Donald and with country of residence address.
3. **NAD+DDT+++BARRET:TODD '** Indicates an 'In Transit' Crew member.
4. **NAD+FM+++CALIBRE:STEPHAN:T '** Indicates a Crew Member.
5. **NAD+DDU+++SORENSEN:YNGVAR:L '** Indicates an 'In Transit' Passenger.

4.13 ATT: ATTRIBUTE - GR. 4

Function: To identify the gender of the passenger or crew member.

Composite/Data Element	No.	Field Type	Comm Usage	Status	Max Rep.	Code Set	Comp.	Values / Comments
<b>ATTRIBUTE FUNCTION CODE QUALIFIER</b>	9017	an..3	a1	M	1	Yes	-	2
ATTRIBUTE TYPE	C955			N/A			-	
Attribute type description	9021	an..17		N/A				
Code list identification code	1131	an..17		N/A				
Code list responsible agency code	3055	an..3		N/A				
Attribute type description	9020	an..70		N/A				
<b>ATTRIBUTE DETAIL</b>	C956	-	-	M	1	-	C956	
<b>Attribute description code</b>	9019	an..17	a1	M	1	Yes	C956	<b>F, M, X, U</b>
Code list identification code	1131	an..17	-	N/A	-	-	-	
Code list responsible agency code	3055	an..3	-	N/A	-	-	-	
Attribute description	9018	an256	-	N/A	-	-	-	

**Example**

**ATT+2++F'** Indicates a female passenger or crew member  
**ATT+2++M'** Indicates a male passenger or crew member

**ATT+2++X'**  
**ATT+2++U'** Indicates when a passenger or crew member does not wish to divulge gender and the Machine Readable Zone of a document has no value (i.e. <). X is the official code according to document 9030

4.14 DTM: DATE/TIME/PERIOD - GR. 4

Function: To specify the date of birth of a passenger or crew member.

Composite/Data Element	No.	Field Type	Comm Usage	Status	Max Rep.	Code Set	Comp.	Values / Comments
<b>DATE/TIME/ PERIOD</b>	C507	-	-	M	1	-	-	
<b>Date or time or period function code qualifier</b>	2005	an..3	a3	M	1	Yes	C507	<b>329</b>
<b>Date or time or period value</b>	2380	an..35	n6	M	1	-	C507	<b>'640217'</b> Format is always 'YYMMDD'
Date or time or period format code	2379	an..3	-	N/A	-	-	-	

**Examples**

**DTM+329:640217'**

Indicates the date of birth of the passenger or crew member  
(i.e. February 17, 1964.)

4.15 MEA: Measurements - GR. 4

Function: To specify physical measurements.

This segment used to report number of Checked Bags.

Composite/Data Element	No.	Field Type	Comm Usage	Status	Max Rep.	Code Set	Comp.	Values / Comments
<b>MEASUREMENT PURPOSE CODE QUALIFIER</b>	6311	an..3	an..2	M	1	Yes	-	'CT' for the number of the baggage. 'WT' for the weight of the baggage.
<b>MEASUREMENT DETAILS</b>	C502	-	-	N/A	1	-	-	
Measured attribute code	6313	an..3	-	N/A	-	-	C502	
Measurement significance code	6321	an..3	-	N/A	-	-	C502	
Non-discrete measurement name code	6155	an..17	-	N/A	-	-	C502	
Non-discrete measurement name	6154	an..70	-	N/A	-	-	C502	
<b>VALUE / RANGE</b>	C174	-	-	C	-	-		
<b>Measurement Unit Code</b>	6411	an..8	a3	C	-	-	C174	'KGM' for Kilograms 'LBR' for Pounds
<b>Measure</b>	6314	an..18	an..3	M			C174	'2'
Range minimum quantity	6162	an..18	-	N/A	-	-	C174	
Range maximum quantity	6152	an..18	-	N/A	-	-	C174	
Significant digits quantity	6432	an..2	-	N/A	-	-	C174	
<b>SURFACE OR LAYER CODE</b>	7383	an..3	-	N/A	-	-	-	

**Examples**

**MEA+CT++:2'**

Indicates that this passenger checked two bags at pre-flight check-in.

**MEA+WT++KGM:28'**

Indicates that this passenger checked 28 Kgs bags at pre-flight check-in.

4.16 GEI: Processing Information - GR. 4

Function: To identify that information for this passenger has been validated.

Composite/Data Element	No.	Field Type	Comm Usage	Status	Max Rep.	Code Set	Comp.	Values / Comments
<b>PROCESSING INFORMATION CODE QUALIFIER</b>	9649	an..3	an..1	M	1	Yes	-	4
<b>PROCESSING INDICATOR</b>	C012	-	-	M	1	-	-	
<b>Processing indicator description code</b>	7365	an..3	an..3	M	1	-	C012	'173' for information verified '174' for information not verified
Code list identification code	1131	an..17		N/A				
Code list responsible agency code	3055	an..3		N/A				
Processing indicator description	7364	an..35		N/A				
<b>PROCESS TYPE DESCRIPTION CODE</b>	7178	an..17		N/A				

**Examples**

**GEI+4+173'** Indicates that the information contained for this passenger has been verified.

4.17 FTX: FREE TEXT - GR. 4

Function: To indicate the description and bag tag numbers of the passenger or crew effects.

Composite/Data Element	No.	Field Type	CommU sage	Status	Max Rep.	Code Set	Comp.	Values / Comments
<b>TEXT SUBJECT CODE QUALIFIER</b>	4451	an..3	An3	M	1	YES	-	<b>BAG</b>
FREE TEXT FUNCTION CODE	4453			N/A				
TEXT REFERENCE	C107			N/A				
Free text description Code	4441	an..17		N/A				
Code list identification code	1131	an..17		N/A				
Code list responsible agency code	3055	an..3		N/A				
TEXT LITERAL	C108	-	-	M	1	-	-	
<b>Free Text</b>	4440	an.512	an.35	M	1		C108	<b>'BA123456'</b>
<b>Free Text</b>	4440	an.512	n..3	C	1		C108	<b>'3'</b>
Free Text	4440	an.512		N/A				
Free Text	4440	an.512		N/A				
Free Text	4440	an.512		N/A				
LANGUAGE NAME CODE	3453	an..3		N/A				
FREE TEXT FORMAT CODE	4447	an..3		N/A				

**Example**

1. **FTX+BAG+++BA987654'** - Single Bag Tag reference
2. **FTX+BAG+++AF012345:3'** - Indicates 3 bags checked beginning with a sequential reference of AF012345.

4.18 LOC: PLACE/LOCATION IDENTIFICATION - GR. 4

Function: To identify the place of birth, the airports related to the journey, and the country of residence of passengers or crew members.

Composite/Data Element	No.	Field Type	Comm Usage	Status	MaxRep.	Code Set	Comp.	Values / Comments
<b>LOCATION FUNCTION CODE QUALIFIER</b>	3227	an..3	n..3	M	1	Yes	-	<b>22, 174, 178, 179, 180</b>
<b>LOCATION IDENTIFICATION</b>	C517	-	-	M	1	-	-	Either Airports related to the journey, Place of Birth or Country of Residence
<b>Location name code</b>	3225	an..35	a3	C	1	Yes	C517	' <b>LIS</b> ' Airport related to journey Or ' <b>CAN</b> ' Country of residence
<b>Code list identification code</b>	1131	an..17	-	C	1	-	C517	No value required but element must be accounted for if data element 3224 included
<b>Code list responsible agency code</b>	3055	an..3	-	C	1	-	C517	No value required but element must be accounted for if data element 3224 included No value required
<b>Location name</b>	3224	an..256	an..35	C	1	-	C517	' <b>AMBER HILL GBR</b> ' Place of Birth
<b>RELATED LOCATION ONE IDENTIFICATION</b>	C519			N/A				
First related location name code	3223	an..25		N/A				
Code list identification code	1131	an..17		N/A				
Code list responsible agency code	3055	an..3		N/A				
First related location name	3222	an..70		N/A				
<b>RELATED LOCATION TWO IDENTIFICATION</b>	C553			N/A				
Second related location name code	3233	an..25		N/A				
Code list identification code	1131	an..17		N/A				
Code list responsible agency code	3055	an..3		N/A				
Second related location name	3232	an..70		N/A				
<b>RELATION CODE</b>	5479	an..3		N/A				

### Examples

1. **LOC+178+LIS'** Indicates the airport where a passenger or crew member began their journey, i.e. Lisbon
2. **LOC+179+ORD'** For intransit passengers or crew members or for progressive clearance flights, indicates the airport where a passenger or crew member will end their journey, i.e. Chicago O'Hare.
3. **LOC+22+BOS'** For intransit passengers or crew members or for progressive clearance flights, indicates the airport where a passenger or crew member will complete clearance procedures, i.e. Boston Logan.
4. **LOC+180+:::AMBER HILL GBR'** Indicates the place of birth as per ICAO Document 9303.
5. **LOC+174+CAN'** Indicates the country of residence as per ICAO Document 9303 ISO 3166 (3 alpha).

4.19 COM: COMMUNICATION CONTACT - GR. 4

Function: To specify the communication number(s) of the passenger. Up to 3

Communication numbers can be provided.

Composite/Data Element	No.	Field Type	Comm Usage	Status	MaxRep.	Code Set	Comp.	Values / Comments
<b>COMMUNICATION CONTACT</b>	C076	-	-	M	3	-	-	
<b>Communication address identifier</b>	3148	an..512	an..35	M	1	-	C076	<b>202 628 9292</b>
<b>Communication address code qualifier</b>	3155	an..3	a2	M	1	Yes	C076	<b>EM, TE, FX</b>

**Example**

**COM+202 628 9292:TE+202 628 4998:FX+davidsonr.at.iata.org:EM'**

Indicates telephone number, fax number and email address of the traveller.

Note: When reporting email addresses, special consideration should be given to any special characters appearing in the email address and potential impact to the syntax delimitation defined in the UNA segment.

4.20 EMP: EMPLOYMENT DETAILS - GR. 4

Function: to indicate the occupation of a passenger or the rank of crew.

Composite/Data Element	No.	Field Type	Comm Usage	Status	MaxRep	Code Set	Comp	Values / Comments
<b>EMPLOYMENT DETAILS CODE QUALIFIER</b>	9003	an..3	an..1	M	1	-	-	1
<b>EMPLOYMENT CATEGORY</b>	C948	-	-	C	1	-	-	
<b>Employment category description code</b>	9005	an..3	an3	M	1	Yes	C948	'CR1' for cockpit crew or individuals inside cockpit 'CR2' for cabin crew 'CR3' for airline operation management with cockpit access 'CR4' for cargo non cockpit crew and/or non-crew individuals. 'CR5' pilots on board but not on duty
<b>Code list identification code</b>	1131	an..17	an3	C	-	-	C948	
<b>Code list responsible agency code</b>	3055	an..3	-	C	-	-	C948	
Employment category description	9004	an..35	-	N/A	-	-	-	
OCCUPATION	C951	-	-	N/A	-	-	-	
Occupation description code	9009	an..3	-	N/A				
Code list identification code	1131	an..17	-	N/A				
Code list responsible agency code	3055	an..3	-	N/A				
Occupation description	9008	an..35	-	N/A				
Occupation description	9008	an..35	-	N/A				
QUALIFICATION CLASSIFICATION	C950			N/A	-			
Qualification classification description code	9007	an..3	-	N/A				
Code list identification code	1131	an..17	-	N/A				
Code list responsible agency code	3055	an..3	-	N/A				
Qualification classification description	9006	an..35	-	N/A				
Qualification classification description	9006	an..35	-	N/A				
PERSON JOB TITLE	3480	an..35	-	N/A	-			

Composite/Data Element	No.	FieldType	Comm Usage	Status	MaxRep	Code Set	Comp	Values / Comments
QUALIFICATION APPLICATION AREA CODE	9035	an..3	-	N/A	-			

**Example**

EMP+1+CR1:110:111' Indicates current passenger is a cockpit crew

4.21 NAT: NATIONALITY - GR. 4

Function: To specify the nationality of the passenger or crew member.

Composite/Data Element	No.	Field Type	Message	Status	Max Rep	Code Set	Comp	Values / Comments
<b>NATIONALITY CODE QUALIFIER</b>	3493	an..3	n1	M	1	Yes	1	2
<b>NATIONALITY DETAILS</b>	C042	-	-	M	1	-	-	ICAO 9303/ISO 3166 codes
<b>Nationality name code</b>	3293	an..3	a3	M	1	-	C042	<b>CAN</b>
Code list identification code	1131	an..17	-	N/A	-	-	-	
Code list responsible agency code	3055	an..3	-	N/A	-	-	-	
Nationality name	3292	an..35	-	N/A	-	-	-	

**Example**

**NAT+2+CAN'**

Indicates current nationality as a Canadian



4.22 RFF: REFERENCE - GR. 4

Function: To specify the passenger reservation reference number. To specify the passenger reservation number, unique passenger reference, and other reference information related to this traveler. Up to 5 occurrences of this segment may be present

Composite/Data Element	No.	Field Type	Comm. Usage	Status	Max Rep.	Code Set	Comp.	Values / Comments
<b>REFERENCE</b>	C506			M	1	-	-	
<b>Reference code qualifier</b>	1153	an..3	a3	M	1	Yes	C506	<b>AVF, ABO, SEA, AEA, CR</b>
<b>Reference identifier</b>	1154	an..70	an..35	M	1	-	C506	<b>'WWHPDS'</b>
Document line identifier	1156	an..6	-	N/A	-	-	-	
Version identifier	1056	an..9	-	N/A	-	-	-	
Revision identifier	1060	an..6	-	N/A	-	-	-	

**Example**

<b>RFF+AVF:WWHPDS'</b>	Indicates passenger reservation reference number
RFF+ABO:BA1321654987'	Indicates Unique Passenger Reference
RFF+SEA:22A'	Indicates assigned Seat identification
RFF+AEA:123456789'	Government agency reference number (Optionally issued by a state to facilitate booking and travel).
RFF+CR:ABC123'	Customer Reference Number. Frequent flyer or frequent traveler reference.

4.23 DOC: DOCUMENT/MESSAGE DETAILS - GR. 5

Function: To identify the official travel document and/or other document used for travel.

Composite/Data Element	No.	Field Type	CommU sage	Status	Max Rep.	Code Set	Comp.	Values / Comments
<b>DOCUMENT/ MESSAGE NAME</b>	C002	-	-	M	1	-	-	Document types as per ICAO 9303
<b>Document name code</b>	1001	an..3	a..2	M	1	Yes	C002	<b>P, V, I</b> <i>See Notes</i>
Code list identification code	1131	an..17	-	N/A	-	-	-	
Code list responsible agency code	3055	an..3	-	N/A	-	-	-	
Document name	1000	an..35	-	N/A	-	-	-	
<b>DOCUMENT/ MESSAGE DETAILS</b>	C503	-	-	M	1	-	-	Document number
<b>Document identifier</b>	1004	an..35	an..9	M	1	-	C503	<b>'98764312'</b>
Document status code	1373	an..3	-	N/A	-	-	-	
Document source description	1366	an..70	-	N/A	-	-	-	
Language name code	3453	an..3	-	N/A	-	-	-	
Version identifier	1056	an..9	-	N/A	-	-	-	
Revision identifier	1060	an..6	-	N/A	-	-	-	
<b>COMMUNICATION MEDIUM TYPE CODE</b>	3153	an..3		N/A				
<b>DOCUMENT COPIES REQUIRED QUANTITY</b>	1220	n..2		N/A				
<b>DOCUMENT ORIGINALS REQUIRED QUANTITY</b>	1218	n..2		N/A				

**Example**

**DOC+P+98764312'** Indicates that the document type is a passport and its number.  
**DOC+V+9891404'** Indicates that the document type is a visa and its number.  
**DOC+I+G123456'** Indicates that the document type is state issued document of identity and its number.

**Notes**

ICAO 9303 document types also include the characters **A, C, I** and may be used to indicate an Identity Card. The exact use will be defined by the Issuing State.

One additional character may be used after P, V, A, C, I to further identify the document at the discretion of the Issuing State. The exact use will be defined by the Issuing State.

Document Type '**AC**' is reserved for use as 'Crew Member Certificate' and Document Type '**IP**' is reserved for use as 'Passport Card'.

States may approve other documents as identification for travel use. Document type codes will be assigned by the Issuing State.

Certain States have agreed to assign code '**F**' to identify 'approved non-standard identity documents used for travel'.

4.24 DTM: DATE/TIME/PERIOD - GR. 5

Function: To specify the expiry date of the official travel document or the issue date of the other document used to travel.

Composite/Data Element	No.	Field Type	Comm Usage	Status	Max Rep	Code Set	Comp.	Values / Comments
<b>DATE/TIME/ PERIOD</b>	C507	-	-	M	1	-	-	
<b>Date or time or period function code qualifier</b>	2005	an..3	n..3	M	1	Yes	C507	<b>36, 182</b>
<b>Date or time or period value</b>	2380	an..35	n6	M	1	-	C507	<b>'150723'</b> Format is always 'YYMMDD'.
Date or time or period format code	2379	an..3	-	N/A	-	-	-	

**Examples**

1. **DTM+36:150723'** Indicates the expiry date of the official travel document (i.e. July 23, 2015).
2. **DTM+182:121006'** Indicates the issue date of the other document used for travel (i.e. October 6, 2012).

4.25 LOC: PLACE/LOCATION IDENTIFICATION - GR. 5

Function: To identify either the country of issue of the official travel document or the place of issue of the other document used for travel.

Composite/Data Element	No.	Field Type	Comm Usage	Status	Max Rep.	Code Set	Comp.	Values / Comments
<b>LOCATION FUNCTION CODE QUALIFIER</b>	3227	an..3	n2	M	1	Yes	-	<b>91</b>
<b>LOCATION IDENTIFICATION</b>	C517	-	-	M	1	-	-	Either Country of Issue of official travel document (data element 3225) or Place of Issue of other document (data element 3224)
<b>Location name code</b>	3225	an..35	a3	C	1	Yes	C517	<b>'CAN'</b> ICAO 9303/ISO 3166 codes
<b>Code list identification code</b>	1131	an..17	-	C	1	-	-	No value required but element must be accounted for if data element 3224 included
<b>Code list responsible agency code</b>	3055	an..3	-	C	1	-	-	No value required but element must be accounted for if data element 3224 included
<b>Location name</b>	3224	an..256	an..35	C	1	-	-	<b>'MONTREAL'</b>
<b>RELATED LOCATION ONE IDENTIFICATION</b>	C519			N/A				
First related location name code	3223	an..35		N/A				
Code list identification code	1131	an..17		N/A				
Code list responsible agency code	3055	an..3		N/A				
First related location name	3222	an..70		N/A				
<b>RELATED LOCATION TWO IDENTIFICATION</b>	C553			N/A				
Second related location name code	3233	an..25		N/A				
Code list identification code	1131	an..17		N/A				
Code list responsible agency code	3055	an..3		N/A				
Second related location name	3232	an..70		N/A				
<b>RELATION CODE</b>	5479	an..3		N/A				

**Examples**

- LOC+91+CAN'** Indicates the State responsible for issuing the passport; i.e. Canada
- LOC+91+:::MONTREAL'** Indicates the city where a travel document was issued

4.26 CNT: CONTROL TOTAL

Function: To provide message control total.

Composite/Data Element	No.	Field Type	CommU sage	Status	Max Rep.	Code Set	Comp.	Values / Comments
<b>CONTROL</b>	C270	-	-	M	1	-	-	
<b>Control total type code qualifier</b>	6069	an..3	n2	M	1	Yes	C270	<b>41, 42</b>
<b>Control total value</b>	6066	n..18	n..4	M	1	-	C270	<b>'160'</b>
Measurement unit code	6411	an..3	-	N/A	-	-	-	

**Notes**

1. The single occurrence of CNT is used to designate the total number of passengers or the total number of crew on a specified flight.
2. If more than one passenger (or crew) message is to be transmitted, the number reported in CNT in each message is the total number of passengers (or crew) on the flight.

It is **NOT** the number of passengers (or crew) being reported in each message.

**Example**

**CNT+42:160'** Indicates a total of 160 passengers on the flight.  
**CNT+41:8'** Indicates a total of 8 crew members on the flight.

4.27 UNT: MESSAGE TRAILER

Function: To end and check the completeness of a message by counting the segments in the message (including UNH and UNT) and validating that the message reference number equates to data element 0062 in the UNH segment.

Composite/Data Element	No.	Field Type	Comm Usage	Status	Max Rep	Code Set	Comp.	Values / Comments
<b>NUMBER OF SEGMENTS IN A MESSAGE</b>	0074	n..10	n..10	M	1	-	-	<b>'2578'</b>
<b>MESSAGE REFERENCE NUMBER</b>	0062	an..14	an..14	M	1	-	-	<b>'MSG001'</b> Must be equal to UNH data element 0062

**Example**

**UNT+2578+MSG001'**

4.28 UNE: FUNCTIONAL GROUP TRAILER

Function: To end and check the completeness of a Functional Group.

Composite/Data Element	No.	Field Type	Comm Usage	Status	Max Rep	Code Set	Comp.	Values / Comments
<b>NUMBER OF MESSAGES</b>	0060	n..6	n..6	M	1	-	-	'1'
<b>APPLICATION SENDER IDENTIFICATION</b>	0048	an..14	an..14	M	1	-	-	'00000001' Must be equal to UNG data element 0048

**Example**

**UNE+1+00000001'**

4.29 UNZ: INTERCHANGE TRAILER

Function: To end and check the completeness of an Interchange.

Composite/Data Element	No.	Field Type	Comm Usage	Status	Max Rep	Code Set	Comp.	Values / Comments
INTERCHANGE CONTROL COUNT	0036	n..6	n..6	M	1	-	-	'1'
INTERCHANGE CONTROL REFERENCE	0020	an..14	an..14	M	1	-	-	'000000001' Must be equal to UNB data element 0020

Example

UNZ+1+000000001'

## NOTES:

- 1.) The UNG Segment is optional for use on the PAXLST message. Use of this segment will be determined by Border Control Agencies.
- 2.) The use of the label 'CUSTOMS' in the examples is for illustrations purposes only. The actual value appearing in the UNB *Interchange Receiver ID* and UNG *Application Receiver ID* will be established by Border Control Agencies in their bilateral agreements with the Carriers.

### 5.1 Single Sector Flight - Passenger

This sample PAXLST illustrates the sum of all segments and many segment examples shown in Section 4 of this Appendix. This PAXLST message identifies a single, non-progressive flight and a single passenger.

```
UNB+UNOA:4+ZZAIRLINE+CUSTOMS+130620:0900+000000001'  
UNG+PAXLST+ZZAIRLINE+CUSTOMS+130620:0900+000000001+UN+D:15B'  
UNH+PAX001+PAXLST:D:15B:UN:IATA'  
BGM+745'  
RFF+TN:1234567890'  
NAD+MS+++DAVIDSON:ROBERT'  
COM+202 628 9292:TE+202 628 4998:FX+DAVIDSONR.AT. IATA.ORG:EM'  
TDT+20+ZZ123+++ZZ'  
LOC+125+SYD'  
DTM+189:1306210900:201'  
LOC+87+HNL'  
DTM+232: 1306212200:201'  
NAD+FL+++WILLIAMS:JOHN:DONALD+235 WESTERN ROAD SUITE 203+  
SLEAFORD+:::LINCS+PE224T5+GBR'  
ATT+2++M'  
DTM+329:720907'  
MEA+CT++:2'  
GEI+4+174'  
FTX+BAG+++ZZ012345:3'  
LOC+22+HNL'  
LOC+174+GBR'  
LOC+178+SYD'  
LOC+179+HNL'  
LOC+180+:::AMBER HILL GBR'  
COM+44 188 84 14151:TE'  
NAT+2+GBR'  
RFF+AVF:TYR123'  
RFF+ABO:ABC123'  
DOC+P+MB140241'  
DTM+36:151231'  
LOC+91+GBR'  
CNT+42:160'  
UNT+30+PAX001'  
UNE+1+000000001'  
UNZ+1+000000001'
```

## 5.2 Sample Crew Reporting Message

This sample PAXLST identifies as single flight with a Crew Member clearing at the destination.

```
UNB+UNOA:4+ZZAIRLINE+CUSTOMS+130620:0900+QF00321'  
UNG+PAXLST+ZZAIRLINE+CUSTOMS+130620:0900+81+UN+D:15B'  
UNH+PAX001+PAXLST:D:15B:UN:IATA'  
BGM+250'  
NAD+MS+USD090746'  
TDT+20+ZZ123+++ZZ'  
LOC+125+SYD'  
DTM+189:1306210900:201'  
LOC+87+HNL'  
DTM+232:1306212200:201'  
NAD+FM+++CLARK:MICHAEL+ 2365 KAA NAPALI HIGHWAY  
+LAHAINA+HI+ 96761'  
ATT+2++M'  
DTM+329:720907'  
NAT+2+CAN'  
LOC+22+HNL'  
LOC+174+CAN'  
LOC+178+SYD'  
LOC+179+HNL'  
DOC+P+MB140241'  
DTM+36:151021'  
LOC+91+CAN'  
CNT+41:8'  
UNT+20+PAX001'  
UNE+1+81'  
UNZ+1+QF00321'
```

### 5.3 Progressive Flight with Domestic Continuance – Passenger

This sample identifies a PAXLST message with two passengers arriving in one country and continuing to another destination within the same country.

```
UNB+UNOA:4+ XYZAIRLINES+CUSTOMS+140708:0601+123456789'  
UNG+PAXLST+XYZAIRLINES+CUSTOMS+140708:0601+12345+UN+D:15B'  
UNH+123+PAXLST:D:15B:UN:IATA'  
BGM+745'  
RFF+TN:BART34567890:::1'  
NAD+MS+++XYZ PSGR SYSTEMS'  
COM+703-555-1212:TE+703-555-4545:FX'  
TDT+20+XZ877+++XZ'  
LOC+92+BCN'  
DTM+189:1407081100:201'  
LOC+92+IAD'  
DTM+232:1407081700:201'  
TDT+20+ZX877+++XZ'  
LOC+92+IAD'  
DTM+189:14070811930:201'  
LOC+92+SFO'  
DTM+232:14070812330:201'  
NAD+FL+++MARTINEZ:JULIO:XAVIER'  
ATT+2++M'  
DTM+329:680223'  
LOC+22+IAD'  
LOC+178+BCN'  
LOC+179+SFO'  
LOC+174+ESP'  
NAT+2+ESP'  
RFF+AVF:GJO3RT'  
RFF+ABO:XZ877001'  
DOC+P+YY3478621'  
DTM+36:181230'  
LOC+91+ESP'  
NAD+FL+++MARTINEZ:SORINA:MARIA'  
ATT+2++F'  
DTM+329:690606'  
LOC+22+IAD'  
LOC+178+BCN'  
LOC+179+SFO'  
LOC+174+ESP'  
NAT+2+ESP'  
RFF+AVF:GJO3RT'  
RFF+ABO:XZ877002'  
DOC+P+TRQWE9980'  
DTM+36:170916'  
LOC+91+ESP'  
CNT+42:2'  
UNT+43+123'
```

UNE+1+12345'  
UNZ+1+123456789'

#### 5.4 Sample PAXLST using UNA Service String Advice Segment

This sample illustrates a PAXLST message that begins with a UNA segment to specify the service characters (delimitation syntax) used within the interchange. The UNA segment is required when characters other than the default service characters are used in the message.

```
UNA:(.) -  
UNB(UNOA:4(QCAIR(CUSTOMS(131221:0100(160415-  
UNG(PAXLST(QCAIR(CUSTOMS(131221:0100(0834343434(UN(D:15B-  
UNH(1115(PAXLST:D:15B:UN:IATA-  
BGM(745-  
NAD(MS(((QC OPERATIONS-  
COM(88 65414646:TE(88 65458341:FX-  
TDT(20(QC0211(((QC-  
LOC(125(ICN-  
DTM(189:1311221740:201-  
LOC(87(SFO-  
DTM(232:1312211115:201-  
NAD(FL(((CHARLES:JOHNATHAN:T-  
ATT(2((M-  
DTM(329:570619-  
LOC(22(SFO-  
LOC(174(IND-  
LOC(178(HYD-  
LOC(179(SFO-  
NAT(2(CAN-  
RFF(AVF:L6RESU-  
RFF(ABO:000000001L6RESU-  
DOC(P(T6735770-  
DTM(36:160705-  
LOC(91(CAN-  
CNT(42:129-  
UNT(23(1115-  
UNE(1(0834343434-  
UNZ(1(160415-
```

## 5.5 Flight Close-Out PAXLST Message

This sample illustrates a PAXLST message that may be used to report a Flight Close-Out message that identifies all passengers who boarded the flight identified in the message. In this example, passengers are identified only by Passenger Record Locator and Unique Passenger Reference (RFF qualifiers 'AVF' and 'ABO' respectively). The expectation, in this example, is that the passenger names (travel documentation, etc.) were collected through previously transmitted PAXLST API submissions.

```
UNB+UNOA:4+XYZ+CUSTOMS+130322:0335+0000001++API'  
UNG+PAXLST+XYZ AIRLINES+CUSTOMS+130322:0335+1+UN+D:15B'  
UNH+5755176+PAXLST:D:15B:UN:IATA'  
BGM+266+CLOB'  
RFF+TN:ABC1234:::1'  
TDT+20+YZ567+++AA'  
LOC+125+LHR'  
DTM+189:1303221615:201'  
LOC+87+LAX'  
DTM+232:1303221905:201'  
NAD+ZZZ'  
RFF+AVF:TYR123'  
RFF+ABO:TYL001'  
NAD+ZZZ'  
RFF+AVF:TYR123'  
RFF+ABO:TYL002'  
NAD+ZZZ'  
RFF+AVF:TYR123'  
RFF+ABO:TYL003'  
NAD+ZZZ'  
RFF+AVF:TYR123'  
RFF+ABO:TYL004'  
NAD+ZZZ'  
RFF+AVF:AABD55'  
RFF+ABO:MCO001'  
NAD+ZZZ'  
RFF+AVF:AABD55'  
RFF+ABO:MCO002'  
NAD+ZZZ'  
RFF+AVF:ZMJO6O'  
RFF+ABO:VEF001'  
CNT+42:7'  
UNT+31+5755176'  
UNE+1+1'  
UNZ+1+0000001'
```

### APPENDIX A – Data Element List

This Section provides data element codes lists that are used in the air mode PAXLST message. For a complete data element code list, refer to the UN Code Set Directory.

**1001 Document name code**

Desc: Code specifying the document name.

Repr: an..3

- 250 Crew list declaration  
Declaration regarding crew members aboard the conveyance.
- 745 Passenger list  
Declaration to Customs regarding passengers aboard the conveyance;  
equivalent to IMO FAL 6.
- 266 Transport equipment status change report  
Report on one or more changes of status associated with an item or items of  
transport equipment. (This code value is used to indicate change in flight status).
- 336 Customs crew and conveyance  
Document/message contains information regarding the crew list and conveyance.
- 655 Gate pass  
Document/message authorizing goods specified therein to be brought out of a  
fenced-in port or terminal area.

***ICAO 9303 Document Types***

- P Passport
- V Visa
- A Identity Card (exact use defined by the Issuing State)
- C Identity Card (exact use defined by the Issuing State)
- I Identity Card (exact use defined by the Issuing State)
- AC Crew Member Certificate
- IP Passport Card

***Other Document Types***

- F Approved non-standard identity documents used for travel  
(exact use defined by the Issuing State).

**1153 Reference code qualifier**

Desc: Code qualifying a reference.

Repr: an..3

- AVF Passenger reservation reference number  
Number assigned by the travel supplier to identify the passenger reservation
- ABO Unique originating passenger reference  
Reference to supplement the passenger reference number
- AEA Government agency reference number  
Optionally issued by a controlling agency state to facilitate  
booking and travel for a passenger.
- CR Customer reference number  
Frequent flyer or frequent traveler reference.
- SEA Allocated seat

Reference to a seat allocated to a passenger.

**2005 Date or time or period function code qualifier**

Desc: Code qualifying the function of a date, time or period.

Repr: an..3

- 36 Expiry date  
Date of expiry of the validity of a referenced document, price information or any other referenced data element with a limited validity period
- 182 Issue date  
Date when a document/message has been or will be issued.
- 189 Departure date/time, scheduled  
Date (and time) of scheduled departure of means of transport
- 232 Arrival date/time, scheduled  
Date (and time) of scheduled arrival of means of transport
- 329 Birth date/time  
Date/time when a person was born.

**2379 Date or time or period format code**

Desc: Code specifying the representation of a date, time or period.

Repr: an..3

- 201 YYMMDDHHMM  
Calendar date including time without seconds  
Y = Year; M = Month; D = Day; H = Hour; M = Minute.

**3035 Party function code qualifier**

Desc: Code giving specific meaning to a party.

Repr: an..3

- DDT In transit crew member  
The movement of a crew member from one country to another via the territory of an intermediate country for which no entry is intended.
- DDU In transit passenger  
The movement of a passenger from one country to another via the territory of an intermediate country for which no entry is intended.
- FL Passenger  
A person conveyed by a means of transport, other than the crew.
- FM Crew member  
A person manning a means of transport.
- MS Document/message issuer/sender  
Issuer of a document and/or sender of a message.
- ZZZ Flight Close reporting

**3155 Communication address code qualifier**

Descr: Code qualifying the communication address.

Repr: an..3

- EM Electronic mail  
Exchange of mail by electronic means.
- FX Telefax  
Device used for transmitting and reproducing fixed graphic material (as printing) by means of signals over telephone lines or other electronic transmission media.
- TE Telephone  
Voice/data transmission by telephone.

### 3225 Place/Location Identification

Refer to ATA/IATA defined three letter airport codes as published in the IATA Airline Coding Directory. For States responsible for issuing official documents, refer to ICAO Doc 9303/ISO 3166.

### 3227 Location function code qualifier

Desc: Code identifying the function of a location.

Repr: an..3

- 22 Customs office of clearance  
Place where Customs clearance procedure occur.
- 87 Place/port of conveyance initial arrival  
Place/port in the country of destination where the conveyance initially arrives from the "Last place/port of call of conveyance" (125).
- 91 Place of document issue  
The place or location where a document is issued.
- 92 Routing  
Indication of a routing place.  
*[PAXLST: Other places/ports within the same State or Country where the referenced flight is scheduled to land (i.e. a progressive flight)].*
- 125 Last place/port of call of conveyance  
Conveyance departed from this last foreign place/port of call to go to "Place/port of conveyance initial arrival" (87).
- 130 Place of ultimate destination of conveyance  
Seaport, airport, freight terminal, rail station or other place to which a means of transport is ultimately destined.  
*[PAXLST: Place of ultimate destination of conveyance" within the same State/Country for progressive flights.]*
- 174 Place of residence  
A place where a party lives.  
*[PAXLST: Country of Primary Residence]*
- 178 Port of embarkation  
Port where the person embarks onto the conveyance.  
*[PAXLST: Place where passenger began the current journey]*
- 179 Port of disembarkation  
Port where the person disembarks from the conveyance.  
*[PAXLST: Place where passenger will terminate the current journey]*
- 180 Place of birth  
Place where the person was born.

### 3493 Nationality code qualifier

Desc: Code qualifying a nationality.

Repr: an..3

- 2 Current nationality  
Current nationality.

### 4451 Text Subject code qualifier

Desc: Code qualifying the subject of the test.

Repr: an..3

- BAG Passenger baggage information  
Information related to baggage tendered by a passenger, such as odd size indication, tag

### 6069 Control total type code qualifier

Desc: Code qualifying the type of control of hash total.  
Repr: an..3

- 41 Total number of crew  
The total number of crew.
- 42 Total number of passengers  
The total number of passengers aboard the conveyance.

**6311 Measurement purpose code qualifier**

Desc: Code qualifying the purpose of the measurement.  
Repr: an..3

- CT Counts.
- WT Weights.

**6411 Measurement purpose code qualifier**

Desc: Code qualifying the purpose of the measurement.  
Repr: an..8

- KGM Kilograms.
- LBR Pounds.

**7365 Processing indicator description code**

Desc: Code specifying a processing indicator.

- 173 Information, verified  
The information has been verified.
- 174 Information, not verified  
The information has not been verified.

**8051 Transport stage code qualifier**

Desc: Code qualifying a specific stage of transport  
Repr: an..3

- 20 Main-carriage transport  
The primary stage in the movement of cargo from the point of origin to the intended destination  
*[PAXLST: The flight for which API is applicable.]*
- 34 Overflight  
The movement of a conveyance through the airspace over the territories of a country without landing within the territories of the country  
*[PAXLST: The flight for which over-flight API is applicable.]*

**9005 Employment category description code**

Desc: Code qualifying Employment Category  
Repr: an3

- CR1 cockpit crew or individuals inside cockpit
- CR2 cabin crew
- CR3 airline operation management with cockpit access
- CR4 for cargo non cockpit crew and/or non-crew individuals.
- CR5 pilots on board but not on duty

**9017 Attribute function code qualifier**

Desc: Code qualifying an attribute function.  
Repr: an..3

2      Person  
      Attribute refers to a person

**9019 Attribute Description Code**

Desc: Code specifying an attribute.

Repr: an..3

***ICAO 9303 Sex Types***

M      Male

F      Female

X      Unknown

***Other Sex Types***

U      Unknown

--- END ---