

**APPENDIX IIB
ADVANCED PASSENGER INFORMATION GUIDELINES**

(DISPONIBLE EN ANGLAIS UNIQUEMENT)

Pour les modifications apportées aux lignes directrices de mise en œuvre de message, s'il vous plaît voir la version anglaise.

**WCO/IATA/ICAO
API RESPONSE MESSAGE
(CUSRES)**

IMPLEMENTATION GUIDE

[Relevant for the interactive API Mode]

APRIL 2016

As this Guide is considered to be a living document, potential developers and users of the CUSRES message are recommended to confirm with the WCO, ICAO or IATA that they are in possession of the latest version.

Change log

	Description	Date	Remarks
1.	Update of the CUSRES MIG	25/02/2013	Based on Data Maintenance Requests received in the 5th and the 6th meetings of the API Contact Committee
2	Update of the CUSRES MIG	23/01/2013	Based on Data Maintenance Requests received in the 10th meeting of the API Contact Committee

Interactive API RESPONSE MESSAGE (CUSRES) IMPLEMENTATION GUIDE

TABLE OF CONTENTS

1.0	INTRODUCTION	2
2.0	MESSAGE RELATIONSHIPS	3
3.0	MESSAGE STRUCTURE FOR THE CUSRES MESSAGE	4
3.1	APPLICATION SEGMENTS USED IN THE WCO/IATA/ICAO CUSRES MESSAGE.....	4
3.2	UNITED NATIONS SERVICE SEGMENTS.....	5
4.0	SEGMENT DETAILS FOR USE IN THE CUSRES MESSAGE	6
4.1	UNA: SERVICE STRING ADVICE	7
4.2	UNB: INTERCHANGE HEADER.....	8
4.4	UNH: MESSAGE HEADER.....	12
4.5	BGM: BEGINNING OF MESSAGE	14
4.6	RFF: REFERENCE - GR. 3.....	15
4.7	DTM: DATE/TIME/PERIOD - GR. 3.....	16
4.8	LOC: PLACE/LOCATION IDENTIFICATION – GR.3.....	17
4.9	ERP: ERROR POINT DETAILS - GR. 4	19
4.10	RFF: REFERENCE - GR. 4.....	20
4.11	ERC: APPLICATION ERROR INFORMATION - GR. 4.....	21
4.12	FTX: FREE TEXT - GR. 4	22
4.13	UNT: MESSAGE TRAILER	23
4.14	UNE: FUNCTIONAL GROUP TRAILER	24
4.15	UNZ: INTERCHANGE TRAILER.....	25
5.0	CUSRES MESSAGE EXAMPLES	26
5.3	SINGLE SECTOR FLIGHT RESPONSE MESSAGE – ONE PASSENGER	26
5.2	PROGRESSIVE FLIGHT RESPONSE MESSAGE – ONE PASSENGER	27
5.3	SINGLE SECTOR FLIGHT RESPONSE MESSAGE – TWO PASSENGERS	27
5.5	SINGLE SECTOR FLIGHT RESPONSE MESSAGE – ONE PASSENGER – SPECIAL INSTRUCTIONS.....	30
5.6	RESPONSE MESSAGE – INVALID ITINERARY DATA.....	31
A.	5.7 RESPONSE MESSAGE – SIMPLE ACKNOWLEDGEMENT.....	32
	APPENDIX A – DATA ELEMENT LIST	33

iAPI RESPONSE MESSAGE (CUSRES) IMPLEMENTATION GUIDE

This Document includes all the data requirements agreed by the WCO, IATA and ICAO and should be used as a basis for development of the air mode CUSRES response message.

The WCO Council formally adopted the Advanced Passenger Information Guidelines and this Implementation Guide in MMMM 2013.

IATA formally adopted the CUSRES message in MMMM 2013.

1.0 INTRODUCTION

The efforts to develop the first version of the iAPI (Interactive API) CUSRES Response Message Guidelines was undertaken in 2009 by the WCO, IATA, and ICAO. This effort was in response to Border Control Agencies desire to develop interactive, request/reply type applications for purposes of providing a positive acknowledgement and response message to the Air Carrier's systems.

This Guideline contains the specifications for the WCO/IATA subset of the UN/EDIFACT CUSRES message, designed as multi-modal, multi-functional message.

In **October** 2012, the WCO IATA ICAO Contact Committee updated the API Guidelines and reached agreement on a revised set of API data requirements that shall now include this iAPI CUSRES Response Message Specification. This document identifies the maximum number of data elements that carriers may expect to receive within a response CUSRES message, following reporting of Advanced Passenger Information (API) to Border Control Agencies.

The set of required data elements have been mapped into the WCO/IATA subset of the UN/EDIFACT CUSRES message and are detailed within this CUSRES Message Implementation Guide, developed by the WCO and IATA.

The purpose of this Guide is to aid Border Control Agencies and carriers in the understanding of the UN/EDIFACT CUSRES message before beginning detailed development and implementation.

This Guide contains the CUSRES message branching diagram and describes the function and use of each segment within its relative position within the message. Examples on a segment basis and on a message basis are also included.

2.0 MESSAGE RELATIONSHIPS

The CUSRES is a standalone batch message that, when implemented in an *Interactive* API program may be returned to the Air Carrier in response to a PAXLST message. The CUSRES may be used by Border Control Agencies as a multi-functional message. The CUSRES may be implemented for purposes of providing any of the following:

1. Simple *acknowledgement* for receipt of a PAXLST;
2. Reporting errors on the received PAXLST;
3. Provide a *status* applicable to the passenger information contained within the PAXLST message and updates to an active passenger's status.

The agreed data requirements for the WCO/IATA/ICAO CUSRES message are identified below for the purpose of system design. As the CUSRES message is a direct response for the receipt of a PAXLST message by Border Control Agencies, much of the information on the CUSRES shall be populated with information that was present on the PAXLST.

Control Information (All optional)

- Interchange Control Reference
- Group Reference Number
- Message Reference Number
- Common Access Reference
- Transaction Reference Number

Flight Information (Itinerary Data)

- Airline Code and Flight Number
- Last Place/Port of Call for Aircraft
- Place/Port of Initial Arrival for Aircraft
- Scheduled Local Departure Dates/Times
- Scheduled Local Arrival Dates/Time
- Subsequent Place(s)/Port(s) of Call within the Country (for Progressive Flights)
- Place/Port of Final Destination within the Country (for Progressive Flights)

Message Status Indicators

- General Acknowledgement
- Detailed Acknowledgement
- Textual Guidance

Data relating to each individual passenger :

- Passenger Reference
- Status Indicator

3.0 MESSAGE STRUCTURE FOR THE CUSRES MESSAGE

This message specification is based on the UN/EDIFACT Response (CUSRES) Message and is specific to the air mode. It provides for the reporting of message acknowledgement and status of the passenger data by Border Control Agencies that have received and processed an interactive PAXLST message.

The basic concept of the CUSRES message is that one CUSRES Response Message shall be generated by a Border Control Authority in response to *each* individual PAXLST sent by the Air Carrier system.

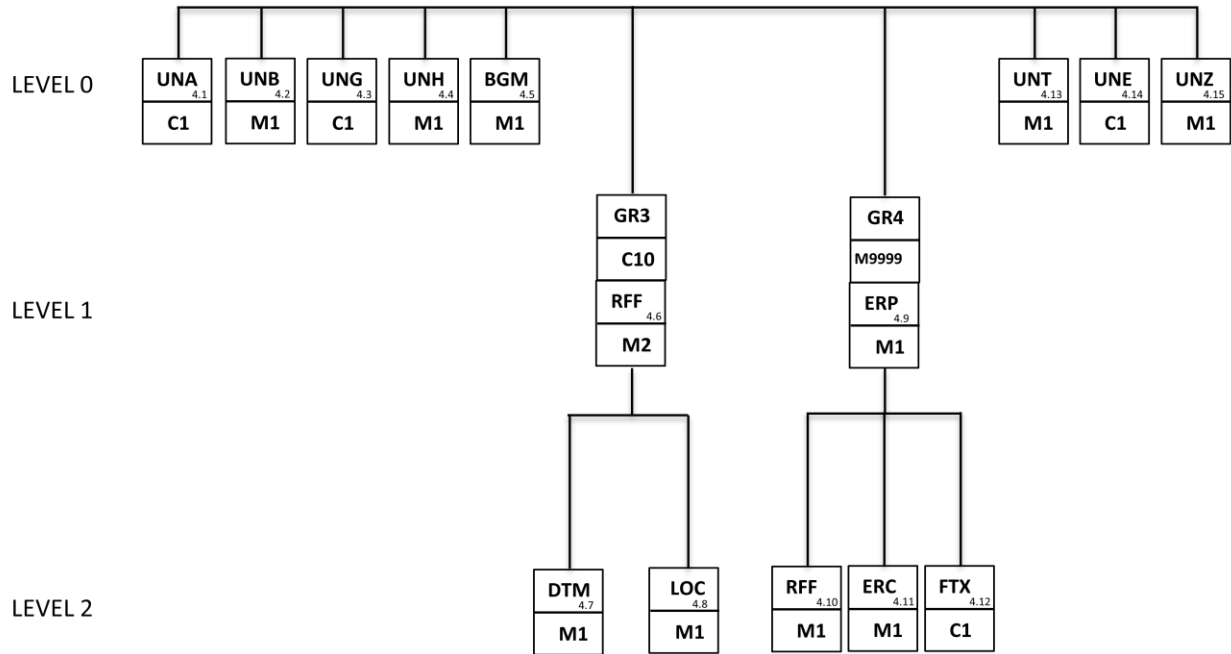

3.1 APPLICATION SEGMENTS USED IN THE WCO/IATA/ICAO CUSRES MESSAGE

The segments included in the air mode implementation of CUSRES are:

- BGM Beginning of Message
- DTM Date/Time/Period
- ERC Application Error Information
- ERP Error Point Details
- FTX Free Text
- LOC Place/Location Identification
- RFF Reference
- UNA Service Segment Advice
- UNB Interchange Header
- UNE Functional Group Trailer
- UNG Functional Group Header
- UNH Message Header
- UNT Message Trailer
- UNZ Interchange Trailer

It should be noted that the UN/EDIFACT CUSRES message includes other segments not included in the list above.

3.2 UNITED NATIONS SERVICE SEGMENTS

The UN Service Segments UNA, UNB and UNZ should be implemented as they are described in ISO 9735 Application Level Syntax Rules - Version 4. The use of the UNG and UNE segment pair is optional within UN/EDIFACT message syntax.

Data requirements for these segments are determined on a bilateral basis between individual carriers and respective Border Control Agencies.

4.0 SEGMENT DETAILS FOR USE IN THE CUSRES MESSAGE

This Section provides a detailed table for each segment, in their relative position within the CUSRES message.

Each segment table contains the defined UN/EDIFACT composite element(s), data element(s) and their associated names, numbers and formats.

Each table also contains the CUSRES format and status (Mandatory, Conditional or Not Applicable) of the elements within the segment, the number of repetitions, and the indication of a code set.

The elements that may be used in each segment are indicated by **bolding** the element name.

M or **C** in the Status column indicate a Mandatory or Conditional element.

N/A in the Status column indicates that there is no requirement to populate this field.

Additional comments on the use of the elements are also provided.

Code set values that may be used in each segment are provided in **BOLD** text.

Examples of other values are provided in ***BOLD ITALICISED*** text within quotation marks.

4.1 UNA: SERVICE STRING ADVICE

Function: The Service String Advice (UNA) is Conditional and provides the capability to specify the service characters (delimitation syntax) used within the interchange. The UNA service string advice **must** be used if the service characters differ from the defaults. The UNA is optional if the default characters are used in a typical *Interactive API* process, the CUSRES message *should* contain the same delimitation syntax that was present in the PAXLST message set. Therefore, the service string advice segment **should** appear on the CUSRES Response Message containing the *same* delimitation character set that was present on the PAXLST message being acknowledged or responded to.

The UNA segment shall appear immediately before the interchange header segment. The service string advice shall begin with the upper case characters UNA immediately followed by six characters in the order shown below. The same character shall not be used in more than one position of the UNA.

Default Service Characters		
Name	Graphic Representation	Functionality
Colon	:	Component Data Element Separator
Plus sign	+	Data Element Separator
Question mark	?	Release Character
Asterisk	*	Repetition Separator
Apostrophe	'	Segment Terminator

Composite/Data Element	No.	Field Type	Comm Usage	Status	Max Rep	Code Set	Comp.	Values / Comments
COMPONENT DATA ELEMENT SEPARATOR	UNA1	n1	n1	M	-	-	-	
DATA ELEMENT SEPARATOR	UNA2	n1	n1	M	-	-	-	
DECIMAL MARK	UNA3	n1	n1	M	-	-	-	
RELEASE CHARACTER	UNA4	n1	n1	M	-	-	-	
REPETITION SEPARATOR	UNA5	n1	n1	M	-	-	-	
SEGMENT TERMINATOR	UNA6	n1	n1	M	-	-	-	

Example: UNA:+.?) – In this example, the right-parens represents the exception to the default Segment Terminator.

4.2 UNB: INTERCHANGE HEADER

Function: To start, identify and specify an interchange.

The conditional Status (C) of elements within this segment is used to indicate that Border Control Authorities may establish bilateral requirements for these data elements.

Composite/Data Element	No.	Field Type	Comm Usage	Status	Max Rep	Code Set	Comp.	Values / Comments
SYNTAX IDENTIFIER	S001	-	-	M	1	-	-	
Syntax identifier	0001	a4	a4	M	1	-	S001	UNOA
Syntax version number	0002	n1	n1	M	1	-	S001	4
INTERCHANGE SENDER	S002	-	-	M	1	-	-	
Sender identification	0004	an..35	an..35	M	1	-	S002	'NZCS' (for example) Sender of the message (This value is assigned by the implementing agency)
Partner identification code qualifier	0007	an..4	N/A	C	-	-	-	
Address for reverse routing	0008	an..14	N/A	C	-	-	-	
INTERCHANGE RECEIVER	S003	-	-	M	1	-	-	
Recipient identification	0010	an..35	an..35	M	1	-	S003	'AIRLINE1' (for example) Receiver of the message
Partner identification code qualifier	0007	an..4	N/A	C	-	-	-	
Routing address	0014	an..14	N/A	C	-	-	-	
DATE AND TIME OF PREPARATION	S004	-	-	M	1	-	-	
Date of preparation	0017	n6	n6	M	1	-	S004	'130628' The default format is 'YYMMDD' (n6)
Time of preparation	0019	n4	n4	M	1	-	S004	'0900' The default format is 'HHMM' (n4)
INTERCHANGE CONTROL REFERENCE	0020	an..14	an..14	M	1	-	-	'00000001' Will be replicated in UNZ data element 0020
RECIPIENTS REFERENCE PASSWORD	S005	-	N/A	C	-	-	-	
Recipient reference password	0022	an..14	N/A	M	-	-	S005	
Recipient reference password qualifier	0025	an..2	N/A	C	-	-	S005	
APPLICATION REFERENCE	0026	an..14		C				

PROCESSING PRIORITY CODE	0029	a1		C				
ACKNOWLEDGEMENT REQUEST	0031	n1		C				
COMMUNICATIONS AGREEMENT ID	0032	an..35		C				
TEST INDICATOR	0035	n1		C				

Example

UNB+UNOA:4+NZCS+AIRLINE1+130628:0900+000000001'

Note: In a typical *Interactive API* process, much of the content within elements of the UNB segment shall appear on the CUSRES Response Message as they were presented on the PAXLST message being acknowledged or responded to.

4.3 UNG: FUNCTIONAL GROUP HEADER

Function: To head, identify and specify a Functional Group.

The conditional Status (C) of elements within this segment is used to indicate that Border Control Agencies may establish bilateral requirements for these data elements.

Composite/Data Element	No.	Field Type	Comm Usage	Status	Max Rep	Code Set	Comp.	Values / Comments
FUNCTIONAL GROUP IDENTIFICATION	0038	an6	an6	M	1	-	-	CUSRES
APPLICATION SENDER IDENTIFICATION	S006	-	-	M	1	-	-	
Application Sender identification	0040	an..35	an..35	M	1	-	S006	'NZCS' (for example) Sender of the message (This value is assigned by the implementing agency)
Partner identification code qualifier	0007	an..4	N/A	C	-	-	S006	
APPLICATION RECIPIENT IDENTIFICATION	S007	-	-	M	1	-	-	
Application Recipient identification	0044	an..35	an..35	M	1	-	S007	"AIRLINE1" (for example) Receiver of the message
Partner identification code qualifier	0007	an..4	N/A	C	-	-	S007	
DATE AND TIME OF PREPARATION	S004	-	-	M	1	-	-	
Date of preparation	0017	n6	n6	M	1	-	S004	'130628' The default format is 'YYMMDD' (n6)
Time of preparation	0019	n4	n4	M	1	-	S004	'0900' The default format is 'HHMM' (n4)
FUNCTIONAL GROUP REFERENCE NUMBER	0048	an..14	an..14	M	1	-	-	'00000001' Will be replicated in UNE data element 0048
CONTROLLING AGENCY	0051	an..2	an..2	M	1	-	-	UN
MESSAGE VERSION	S008	-	-	M	1	-	-	
Message Type Version Number	0052	an..3	an..3	M	1	-	S008	'D'
Message Type Release Number	0054	an..3	an..3	M	1	-	S008	'12B' See Note.
Association assigned code	0057	an..6		C				
APPLICATION PASSWORD	0058	an..14		C				

Example

UNG+CUSRES+NZCS+AIRLINE1+130628:0900+00000001+UN+D:12B'

Note:

Border Control Agencies may establish bilateral requirements for the value placed in data element 0054.

In a typical *Interactive API* process, much of the content within elements of the UNG segment shall appear on the CUSRES Response Message as they were presented on the PAXLST message being acknowledged or responded to.

4.4 UNH: MESSAGE HEADER

Function: To identify and specify the CUSRES message.

The conditional Status (C) of elements within this segment is used to indicate that Border Control Agencies may establish bilateral requirements for these data elements.

Composite/Data Element	No.	Field Type	Comm Usage	Status	Max Rep	Code Set	Comp.	Values / Comments
MESSAGE REFERENCE NUMBER	0062	an..14	an..14	M	1	-	-	'MSG001' Will be replicated in UNT data element 0062
MESSAGE IDENTIFIER	S009	-	-	M	1	-	-	
Message type	0065	an..6	a6	M	1	-	S009	CUSRES
Message version number	0052	an..3	a1	M	1	-	S009	D
Message release number	0054	an..3	an2	M	1	-	S009	'12B' See Note
Controlling agency, coded	0051	an..2	a2	M	1	-	S009	UN
Association assigned code	0057	an..6	a4	M	1	-	S009	IATA See Note
Code list directory version number	0110	an..6		C			S009	
Message type sub-function identification	0113	an..6		C			S009	
COMMON ACCESS REFERENCE	0068	an..35		C	1			
STATUS OF THE TRANSFER	S010			C	1			
Sequence of transfers	0070	n..2		M			S010	
First and last transfer	0073	a1		C			S010	
MESSAGE SUBSET IDENTIFICATION	S016			C	1			
Message subset identification	0115	an..14		M			S016	
Message subset version number	0116	an..3		C			S016	

Composite/Data Element	No.	Field Type	Comm Usage	Status	Max Rep	Code Set	Comp.	Values / Comments
Message subset release number	0118	an..3		C			S016	
Controlling agency, coded	0051	an..3		C			S016	

Composite/Data Element	No.	Field Type	Comm Usage	Status	Max Rep	Code Set	Comp.	Values / Comments
MESSAGE IMPLEMENTATION GUIDELINE IDENTIFICATION	S017			C	1			
Message implementation guideline identification	0121	an..14		M	1		S017	
Message implementation guideline version number	0122	an..3		C			S017	
Message implementation guideline release number	0124	an..3		C			S017	
Controlling agency, coded	0051	an..3		C			S017	
SCENARIO IDENTIFICATION	S018			C	1			
Scenario identification	0127	an..14		M			S018	
Scenario version number	0128	an..3		C			S018	
Scenario release number	0130	an..3		C			S018	
Controlling agency, coded	0051	an..3		C			S018	

Example

UNH+MSG001+CUSRES:D:12B:UN:IATA'

Notes:

Border Control Agencies may establish bilateral requirements for the value placed in data element 0054.

The use of code value 'IATA' in data element 0057 is used to indicate that airport and airline codes are IATA assigned codes.

In a typical *Interactive API* process, the content of the elements in the UNH segment shall appear on the CUSRES Response Message as they were presented on the PAXLST message being acknowledged or responded to.

4.5 BGM: BEGINNING OF MESSAGE

Function: To indicate that this CUSRES message is a *Response* Message.

Composite/Data Element	No.	Field Type	Comm. Usage	Status	Max Rep.	Code Set	Comp.	Values / Comments
DOCUMENT/ MESSAGE NAME	C002	-	-	M	1	-	-	
Document name code	1001	an..3	n3	M	1	Yes	C002	962, 132, 312
Code list identification code	1131	an..17	-	N/A	-	-	-	
Code list responsible agency code	3055	an..3	-	N/A	-	-	-	
Document name	1000	an..35	-	N/A	-	-	-	
DOCUMENT/MESSAGE IDENTIFICATION	C106							
Document identifier	1004	an..35		N/A				
Version identifier	1056	an..9		N/A				
Revision identifier	1060	an..6		N/A				
MESSAGE FUNCTION CODE	1225	an..3		N/A				
RESPONSE TYPE CODE	4343	an..3		N/A				

Example

- BGM+962'** Indicates response message
- BGM+132'** Unsolicited message
- BGM+312'** Acknowledgement message

4.6 RFF: REFERENCE - GR. 3

Function: To identify the IATA Air Carrier Code and Flight Number, and to identify the Transaction Reference Number that *optionally* may have appeared on the PAXLST message.

Composite/Data Element	No.	Field Type	Comm. Usage	Status	Max Rep.	Code Set	Comp.	Values / Comments
REFERENCE	C506			M	1	-	-	
Reference code qualifier	1153	an..3	a3	M	1	Yes	C506	TN, AF
Reference identifier	1154	an..70	an..35	M	1	-	C506	'OZ1234'
Document line identifier	1156	an..6	-	N/A	-	-	-	
Reference version identifier	4000	an..35	-	N/A	-	-	-	
Revision identifier	1060	an..6	-	C	-	-	-	2

Examples

RFF+AF:OZ1234'

Indicates Air Carrier code and Flight Number

RFF+TN:1234567890'

Indicates Transaction Reference Number

Notes: An RFF segment with a qualifier of 'AF' shall contain the concatenated IATA Air Carrier Code and Flight Number as it appeared on the TDT segment within the PAXLST message. An RFF segment with a qualifier of 'TN' shall contain the optionally provided Transaction Reference Number and Revision Identifier, if it appeared on an RFF segment within the PAXLST message.

Notes :

For States operating Interactive PAXLST messaging (iAPI), the inclusion of the RFF, Transaction Reference Number and its Revision Identifier may be declared Mandatory.

4.7 DTM: DATE/TIME/PERIOD - GR. 3

Function: To specify the departure and arrival dates for a flight.
If required, departure and arrival times may also be specified.

All dates and times will be provided in LOCAL time.

Composite/Data Element	No.	Field Type	Comm Usage	Status	MaxRep.	Code Set	Comp	Values / Comments
DATE/TIME/ PERIOD	C507	-	-	M	1	-	-	
Date or time or period function code qualifier	2005	an..3	n3	M	1	Yes	C507	189, 232
Date or time or period value	2380	an..35	n6 or n10	M	1	-	C507	The default format is 'YYMMDD' (n6) '130628' Other format is 'YYMMDDHHMM' (n10). '1306281205'
Date or time or period format code	2379	an..3	n3	C	1	Yes	C507	'201' If time (HHMM) is included in data element 2380

Examples

DTM+189:1306281205:201'

Indicates the scheduled departure date and time of the flight, (i.e. June 28, 2013 at 12:05 hrs)

Code 201 is used to indicate a YYMMDDHHMM format.

DTM+232:130628'

Indicates the scheduled arrival date of flight (i.e June 28, 2013)

Note: The values in the elements on this segment shall appear as they were presented on the PAXLST message being acknowledged or responded to.

4.8 LOC: PLACE/LOCATION IDENTIFICATION – GR.3

Function: To identify the arrival and departure airports relating to the specified flight.

Airport codes are published in the IATA Airline Coding Directory.

Composite/Data Element	No.	Field Type	Comm Usage	Status	MaxRep	Code Set	Comp.	Values / Comments
LOCATION FUNCTION CODE QUALIFIER	3227	an..3	n..3	M	1	Yes	-	87, 92, 125, 130
LOCATION IDENTIFICATION	C517	-	-	M	1	-	-	IATA Location Identifiers (Airport Codes)
Location name code	3225	an..35	a3	M	1	-	C517	'YUL'
Code list identification code	1131	an..17	-	N/A	-	-	-	
Code list responsible agency code	3055	an..3	-	N/A		-	-	
Location name	3224	an..256	-	N/A		-	-	
RELATED LOCATION ONE IDENTIFICATION	C519			N/A				
First related location name code	3223	an..25		N/A				
Code list identification code	1131	an..17		N/A				
Code list responsible agency code	3055	an..3		N/A				
First related location name	3222	an..70		N/A				
RELATED LOCATION TWO IDENTIFICATION	C553			N/A				
Second related location name code	3233	an..25		N/A				
Code list identification code	1131	an..17		N/A				
Code list responsible agency code	3055	an..3		N/A				
Second related location name	3232	an..70		N/A				
RELATION CODE	5479	an..3		N/A				

Examples

1. For a single sector progressive flight departing Brussels to New York, the following data would be provided.

LOC+125+BRU' Indicates the last airport of departure from a foreign country, i.e. Brussels National

LOC+87+JFK' Indicates the first airport of arrival in the country of destination, i.e. John F Kennedy International, New York

2. For a multi-sector progressive flight departing Heathrow to Vancouver via Montreal and Ottawa, the following data would be provided.

LOC+125+LHR' Indicates the last airport of departure from a foreign country, i.e. London Heathrow

LOC+87+YUL' Indicates the first airport of arrival in the country of destination, i.e. Montreal Dorval

LOC+92+YOW' Indicates the next airport in the country of destination, i.e. Ottawa International

LOC+130+YVR' Indicates the final destination airport in the country of destination, i.e. Vancouver International

Note: The values in the elements on this segment shall appear as they were presented on the PAXLST message being acknowledged or responded to.

4.9 ERP: ERROR POINT DETAILS - GR. 4

Function: To report a status as either a *Header* level response or a *Detail* level response.

Composite/Data Element	No.	Field Type	Comm Usage	Status	MaxRep.	Code Set	Comp	Values / Comments
ERROR POINT DETAILS	C701	-	-	M	9999	-	-	
Message section code	1049	an..3	n1	M	1	Yes	C701	1, 2
Message item identifier	1052	an..35		N/A				
Message sub-item Identifier	1054	n..3		N/A				
ERROR SEGMENT POINT DETAILS	C853			N/A				
Segment tag identifier	9166	an..3		N/A				
Sequence position identifier	1050	an..10		N/A				
Sequence Identifier Source Code	1159	an..3		N/A				

Examples

ERP+1' Identifies Header level response

ERP+2' Identifies Detail level response

4.10 RFF: REFERENCE - GR. 4

Function: To identify the *Reference Identification* for which this response applies.

Composite/Data Element	No.	Field Type	Comm. Usage	Status	Max Rep.	Code Set	Comp.	Values / Comments
REFERENCE	C506			M	1	-	-	
Reference code qualifier	1153	an..3	a3	M	1	Yes	C506	AVF, ABO
Reference identifier	1154	an..70	an..35	M	1	-	C506	see examples below
Document line identifier	1156	an..6	-	N/A	-	-	-	
Reference version identifier	4000	an..35	-	N/A	-	-	-	
Revision identifier	1060	an..6	-	N/A	-	-	-	

Example

RFF+AVF: AX4B31'

Indicates passenger reservation reference number

RFF+ABO:BA1321654987'

Indicates unique passenger reference

4.11 ERC: APPLICATION ERROR INFORMATION - GR. 4

Function: To identify the status code as generated by the Border Control Agency.

Composite/Data Element	No.	Field Type	Comm Usage	Status	MaxRep.	Code Set	Comp	Values / Comments
APPLICATION ERROR DETAIL	C901	-	-	M	1	-	-	
Application Error Code	9321	an..8	an..8	M	1	-	C901	'X', 'ACCEPT' (See Note)
Code list identification code	1052	an..17		N/A				
Code list responsible agency code	1054	an..3		N/A				

Examples

ERC+X'
ERC+ACCEPT'
ERC+ACK'

Note: Border Control Agencies shall establish bilateral agreements for the values appearing in this data element (9321).

4.12 FTX: FREE TEXT - GR. 4

Function: To provide means by which Border Control Agencies may provide special instructions or additional information on the response message.

Composite/Data Element	No.	Field Type	CommU sage	Status	Max Rep.	Code Set	Comp.	Values / Comments
TEXT SUBJECT CODE QUALIFIER	4451	an..3	an3	M	1	YES	-	AAP
FREE TEXT FUNCTION CODE	4453			N/A				
TEXT REFERENCE	C107			N/A				
Free text description Code	4441	an..17		N/A				
Code list identification code	1131	an..17		N/A				
Code list responsible agency code	3055	an..3		N/A				
TEXT LITERAL	C108	-	-	M	1	-	-	
Free Text	4440	an.512	an..80	M	1		C108	'CHECK-IN OK'
Free Text	4440	an.512		N/A	1			
Free Text	4440	an.512		N/A				
Free Text	4440	an.512		N/A				
Free Text	4440	an.512		N/A				
LANGUAGE NAME CODE	3453	an..3		N/A				
FREE TEXT FORMAT CODE	4447	an..3		N/A				

Examples

FTX+AAP+++ CHECK-IN OK'
FTX+ AAP+++ERROR ON PAXLST - ITINERARY'

Note: Border Control Agencies may establish bilateral agreements for the values appearing in data element 4440.

4.13 UNT: MESSAGE TRAILER

Function: To end and check the completeness of a message by counting the segments in the message (including UNH and UNT) and validating that the message reference number equates to data element 0062 in the UNH segment.

Composite/Data Element	No.	Field Type	Comm Usage	Status	Max Rep	Code Set	Comp.	Values / Comments
NUMBER OF SEGMENTS IN A MESSAGE	0074	n..10	n..10	M	1	-	-	'12'
MESSAGE REFERENCE NUMBER	0062	an..14	an..14	M	1	-	-	'MSG001' Must be equal to UNH data element 0062

Example

UNT+12+MSG001'

4.14 UNE: FUNCTIONAL GROUP TRAILER

Function: To end and check the completeness of a Functional Group.

Composite/Data Element	No.	Field Type	Comm Usage	Status	Max Rep	Code Set	Comp.	Values / Comments
NUMBER OF MESSAGES	0060	n..6	n..6	M	1	-	-	'1'
APPLICATION SENDER IDENTIFICATION	0048	an..14	an..14	M	1	-	-	'00000001' Must be equal to UNG data element 0048

Example

UNE+1+00000001'

4.15 UNZ: INTERCHANGE TRAILER

Function: To end and check the completeness of an Interchange.

Composite/Data Element	No.	Field Type	Comm Usage	Status	Max Rep	Code Set	Comp.	Values / Comments
INTERCHANGE CONTROL COUNT	0036	n..6	n..6	M	1	-	-	'1'
INTERCHANGE CONTROL REFERENCE	0020	an..14	an..14	M	1	-	-	'000000001' Must be equal to UNB data element 0020

Example

UNZ+1+000000001'

5.0 CUSRES MESSAGE EXAMPLES

The examples below are presented on a segment-by-segment basis for readability.

5.1 Single Sector Flight Response Message – One Passenger

This example illustrates a CUSRES response message with a status response for a single Passenger. The FTX segment is optional and is not used in this example.

UNB+UNOA:4+ NZCS+API123+080808:0523+000000011'

UNG+CUSRES+ NZCS+123 AIRLINES+080808:0523+11+UN+D:12B'

UNH+RES123+CUSRES:D:12B:UN:IATA'

BGM+962'

RFF+TN:BART34567890:2'

RFF+AF:QQ827'

DTM+189:0808080900:201'

DTM+232:0808081445:201'

LOC+125+CDG'

LOC+87+AKL'

ERP+2' ← Indicates a *Detail* level response

RFF+AVF:GJIO3RT'

RFF+ABO:UUI34T543'

ERC+001' ← Status as reported for the Passenger

UNT+13+RES123'

UNE+1+11'

UNZ+1+000000011'

5.2 Progressive Flight Response Message – One Passenger

This example illustrates a CUSRES response message with a status response for a single Passenger travelling on progressive flights. The RFF segment (GR. 3) shall be repeated for each flight in the itinerary.

```
UNB+UNOA:4+NZCS+SWAIR+020321:1545+000000011'  
UNG+CUSRES+NZCS+SWAIR+020321:1545+11+UN+D:05B'  
UNH+SWCA749+CUSRES:D:05B:UN:IATA'  
BGM+962'  
RFF+AF:SW679'  
RFF+TN:SW784659:::3'  
DTM+189:0203220800:201'  
DTM+232:0203221930:201'  
LOC+125+GVA'  
LOC+87+ICN'  
RFF+AF:SW679'  
DTM+189:0203222100:201'  
DTM+232:0203230245:201'  
LOC+92+ICN'  
LOC+130+AKL'  
ERP+2' ← Indicates a Detail level response  
RFF+AVF:9GRT9U85'  
RFF+ABO:SWAIR00001'  
ERC+A' ← Status as reported for the Passenger  
UNT+17+SWCA749'  
UNE+1+11'  
UNZ+1+000000011'
```

5.3 Single Sector Flight Response Message – Two Passengers

This example illustrates a CUSRES response message with a status response for **two** Passengers. The ERP segment (GR.4) shall be repeated for each passenger status reported on the CUSRES.

```
UNB+UNOA:4+ NZCS+API123+080917:2135+000000011'
```

UNG+CUSRES+ NZCS+123 AIRLINES+080917:2135+11+UN+D:05B'
UNH+RES123+CUSRES:D:05B:UN:IATA'
BGM+962'
RFF+TN:BART34567890:::2'
RFF+TN:BART34567890'
RFF+AF:QQ827'
DTM+189: 0809170900:201'
DTM+232: 0809171445:201'
LOC+125+CDG'
LOC+87+AKL'
ERP+2' ← Indicates a *Detail* level response
RFF+AVF:GJIO3RT'
RFF+ABO:QQ001'
ERC+001' ← Status as reported for Passenger #1
ERP+2'
RFF+AVF:GJIO3RT'
RFF+ABO:QQ002'
ERC+001' ← Status as reported for Passenger #2
UNT+17+RES123'
UNE+1+11'
UNZ+1+000000011'

5.4 Sample CUSRES containing UNA Service String Advice Segment

This example illustrates a CUSRES message that begins with a UNA segment to specify the service characters (delimitation syntax) used within the interchange.

The UNA segment is *required* when characters other than the default service characters are used in the message.

Note: The UNA segment *should* appear on the CUSRES message if it was present on the original PAXLST message set.

UNA:(.) -

UNB(UNOA:4(USADHS(QCAIR(081221:0100(160415-

UNG(CUSRES(USADHS(QCAIR(081221:0100(0834343434(UN(D:05B-

UNH(1(CUSRES:D:05B:UN:IATA-

BGM(962-

RFF(TN:FGT35782:::2'

RFF(AF:QC0211-

DTM(189:0812210740:201-

DTM(232:0812211115:201-

LOC(125(ICN-

LOC(87(SFO-

ERP(2-

← Indicates *Detail* level response

RFF(AVF:L6RESU-

ERC(0-

← Status as reported for the Passenger

UNT(11(1-

UNE(1(0834343434-

UNZ(1(160415-

5.5 Single Sector Flight Response Message – One Passenger – Special Instructions

This example illustrates a CUSRES response message with a status response for a single Passenger and includes special instructions generated by the Border Control Authority. The FTX segment is used to provide additional textual information on the CUSRES message.

```
UNB+UNOA:4+NZCS+API123+100925:1855+1234567890'  
UNG+CUSRES+NZCS+123 AIRLINES+100925: 1855+1+UN+D:05B'  
UNH+1+CUSRES:D:05B:UN:IATA'  
BGM+962'  
RFF+TN:API989:::3'  
RFF+TN:API989'  
RFF+AF:ZZ456'  
DTM+189:1009260900:201'  
DTM+232:1009271055:201'  
LOC+125+ORD'  
LOC+87+AKL'  
ERP+2' ← Indicates Detail level response  
RFF+AVF:BZJ8R7X'  
ERC+X' ← Status as reported for the Passenger  
FTX+AAP+++TRAVEL DOCUMENTATION REQUIRED'  
UNT+13+1'  
UNE+1+1'  
UNZ+1+1234567890'
```

5.6 Response Message – Invalid Itinerary Data

This example illustrates a CUSRES response message reporting that an invalid Date/Time of Arrival appeared on the original PAXLST message. An ERP value of '1' indicates a Header Level status being reported. The FTX segment is used to provide additional textual information on the CUSRES message.

UNB+UNOA:4+AUS1+API123+100927:0545+APIAIR0001'

UNG+CUSRES+AUS1+123 AIRLINES+100927:0545+RES3+UN+D:05B'

UNH+3+CUSRES:D:05B:UN:IATA'

BGM+962'

RFF+TN:API989:::2' ← Response to the second submission by the airline for this passenger or
manifest

RFF+AF:ZZ456'

DTM+189:1009280900:201'

DTM+232:1009271055:201' ← Arrivale Date in error

LOC+125+ORD'

LOC+87+SYD'

ERP+1' ← Indicates *Header* level response

ERC+X' ← Status as reported for the *Message*

FTX+AAP+++INVALID ITINERARY – ARRIVAL DATE-TIME'

UNT+12+3'

UNE+1+RES3'

UNZ+1+ APIAIR0001'

5.7 Response Message – Simple Acknowledgement

This example illustrates a CUSRES response message confirming receipt of a PAXLST. This example is also suitable as a response to a flight closeout message indicating passengers that are actually traveling on a flight, either through the CLNB (those not on board) or CLOB (all those on board) flight close-out message.

```
UNB+UNOA:4+UKSB+DLH+110103:0621+D8L3H9'  
UNG+CUSRES+UKSB+DLH+110103:0621+ D8L3H9+UN+D:05B'  
UNH+1+CUSRES:D:05B:UN:IATA'  
BGM+962'  
RFF+TN:DLH0345001:::4'  
RFF+AF: DLH0345'  
DTM+189:1101031200:201'  
DTM+232:1101031345:201'  
LOC+125+HHN'  
LOC+87+LHR'  
ERP+1'           ← Indicates Header level response  
ERC+ACK'       ← Acknowledged receipt  
UNT+11+1'  
UNE+1+ D8L3H9'  
UNZ+1+ D8L3H9'
```

APPENDIX A – Data Element List

This Section provides data element codes lists that are used in the air mode CUSRES message. For a complete data element code list, refer to the UN Code Set Directory.

1001 Document name code

Desc: Code specifying the document name.

Repr: an..3

- 962 Document Response (Customs)
Document response message permitting transfer of data from Customs to transmitter of the received message.
- 132 Customs Notice (Unsolicited message in relation to an active traveller)
- 312 Acknowledgement
Message providing acknowledgement information

1049 Document name code

Desc: Code specifying a section of a message.

Repr: an..3

- 1 Heading Section
The section of the message being referenced is the header.
- 2 Detail Section
The section of the message being referenced is the detail.

1153 Reference code qualifier

Desc: Code qualifying a reference.

Repr: an..3

- AVF Passenger reservation reference number
Number assigned by the travel supplier to identify the passenger reservation
- ABO Unique originating passenger reference
Reference to supplement the passenger reference number
- AF Airlines Flight Identification Number
Identification of a commercial flight by carrier code and number as assigned by the airline.
- TN Transaction Reference
Reference value optionally assigned by originator of the PAXLST message and returned on the CUSRES.

2005 Date or time or period function code qualifier

Desc: Code qualifying the function of a date, time or period.

Repr: an..3

- 189 Departure date/time, scheduled
Date (and time) of scheduled departure of means of transport
- 232 Arrival date/time, scheduled
Date (and time) of scheduled arrival of means of transport

2379 Date or time or period format code

Desc: Code specifying the representation of a date, time or period.
Repr: an..3
201 YYMMDDHHMM
Calendar date including time without seconds
Y = Year; M = Month; D = Day; H = Hour; M = Minute.

3225 Place/Location Identification

Refer to ATA/IATA defined three letter airport codes as published in the IATA Airline Coding Directory.

For States responsible for issuing official documents, refer to ICAO Doc 9303/ISO 3166.

3227 Location function code qualifier

Desc: Code identifying the function of a location.
Repr: an..3

- 87 Place/port of conveyance initial arrival
Place/port in the country of destination where the conveyance initially arrives from the "Last place/port of call of conveyance" (125).
- 92 Routing
Indication of a routing place.
[PAXLST: Other places/ports within the same State or Country where the referenced flight is scheduled to land (i.e. a progressive flight)].
- 125 Last place/port of call of conveyance
Conveyance departed from this last foreign place/port of call to go to "Place/port of conveyance initial arrival" (87).
- 130 Place of ultimate destination of conveyance
Seaport, airport, freight terminal, rail station or other place to which a means of transport is ultimately destined.
[PAXLST: Place of ultimate destination of conveyance" within the same State/Country for progressive flights.]

4451 Text Subject code qualifier

Desc: Code qualifying the subject of the test.
Repr: an..3

- AAP Response